

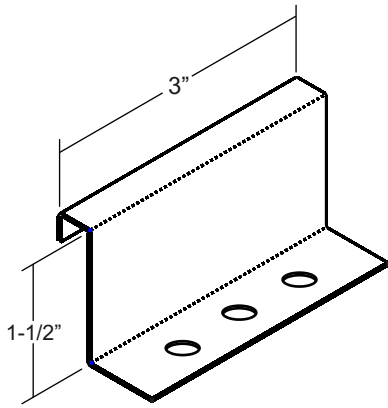

ML150 Panel Accessories Guide

Clip 30



ML150 Clip 30
Fixed clip, 26 gauge Galvanized
For use with panel lengths 30 feet and less

Clip 31

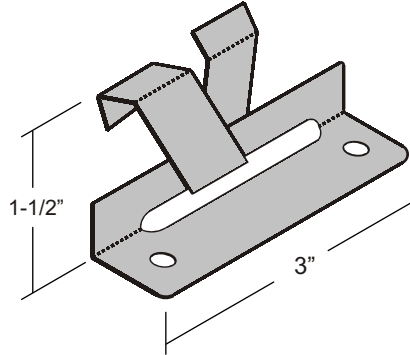

ML150 Clip 31
Butterfly expansion clip, 28 ga. Stainless
Provides up to 1 inch of thermal movement

Clip 32

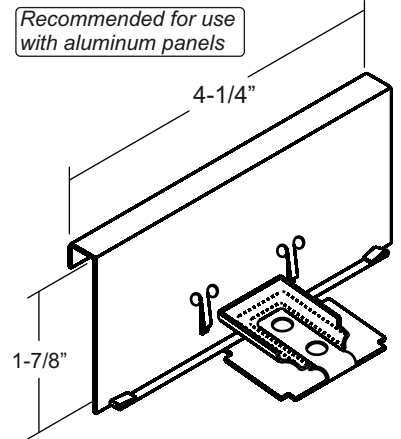

ML150 Clip 32
Expansion Clip, 22 gauge Galvanized
Provides up to 2 inches of thermal movement

Backup Channel

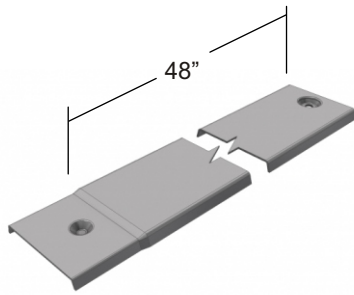

BP148 Backup Channel
3" wide x 48" long, 16 gauge Galvanized
Provides support at panel ends and splices

Bearing Plate

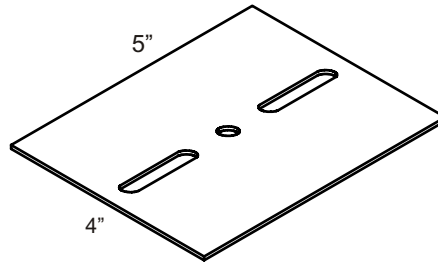

Bearing Plate
4" x 5", 16 gauge Galvanized
For use under clips applied over rigid insulation

Tube Sealant

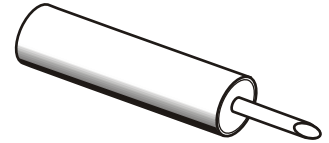

- Ultra 1000 Sealant** (Required for Weather-tight warranty applications)
Colors: Translucent, Gutter Gray, Dark Bronze, White, Sandstone, Red, Green
- Geocel 2300** Tripolymer
Color: Clear
- Polyurethane**
Color: Gray

Tube Sealant
10 oz. tube (estimate 25 lf/tb at 1/4" bead)

Tape Sealant

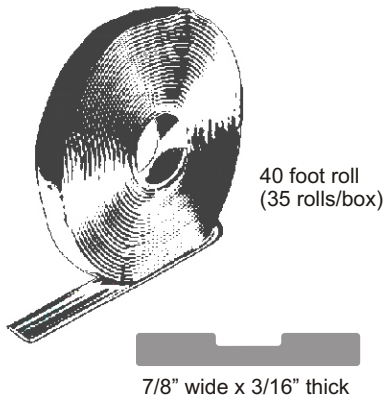

Double Bead Butyl Tape Sealant
7/8" wide x 3/16" thick x 40 foot roll
For use under offset cleats and zee closures

Touch-Up Paint



- 2 oz. can for Kynar colors
- 0.6 oz. bottle for SMP colors

Air Dry Touch-Up Paint
To touch-up small scratches and abrasions
Note: Color match with roof is not guaranteed

Repel™ Underlayment

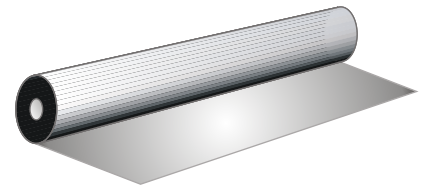

Repel™ Synthetic Underlayment
48" wide x 250' long rolls (10 squares/roll)



ML150 Panel Accessories Guide

Pancake Wood Screw

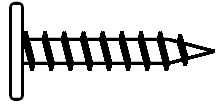

- #10-12 x 1" long
- #10-12 x 1-1/2" long
- #10-12 x 2" long
- #10-12 x 2-1/2" long
- #10-12 x 3" long

#10-12 Pancake Head Wood Screw

Zinc plated, Quadrex bit
For attachment of clips and flashings to wood

Stainless Pancake Screw

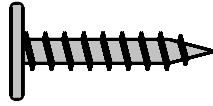

Recommended for use with aluminum panels

#10-12" Pancake Head Wood Screw

Stainless Steel, Quadrex Bit
For attachment of clips and flashings to wood

Pancake Head Self-Driller

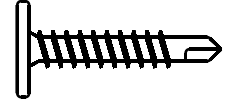

- #10-16 x 1" long
- #12-14 x 1" long

#10-16 or #12-14 Self-Drilling Screw

Zinc Plated, Quadrex bit
For attachment of clips and flashings to steel

Deck Screw



- #14-13 x 1-1/2" long
- #14-13 x 2" long
- #14-13 x 3" long
- #14-13 x 4" long
- #14-13 x 5" long
- #14-13 x 6" long
- #14-13 x 7" long
- #14-13 x 8" long
- #14-13 x 9" long

For use with steel or wood decks. Can be used with aluminum panels

#14-13 Pancake Head DP1 Screws

Tri-Seal™ coating, Square drive bit
To attach clips over rigid insulation into deck

Pop Rivet

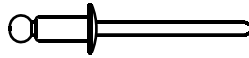

- #1/8 x 3/16" long, Plain or Painted

Pop Rivet, 1/8" Diameter x 3/16" Grip

Stainless Steel Rivet and Mandrel
For sheet metal joining. Pre-drill w/ 1/8" hole.

Lap Tek

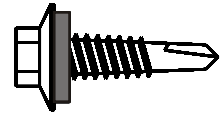

- #1/4-14 x 7/8" long, Plain or Painted

1/4"-14 x 7/8" SD Lap Tek Screw

5/16" HWH w/ washer, Zinc Plated
For sheet metal joining

HWH Wood Screw

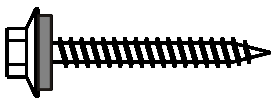

- #10-14 x 1" long, Plain or Painted
- #10-14 x 1-1/2" long, Plain or Painted
- #10-14 x 2" long, Plain or Painted
- #10-14 x 2-1/2" long, Plain or Painted
- #10-14 x 3" long, Plain or Painted

#10-14 Wood Screw

1/4" HWH w/ washer, Zinc Plated
To attach sheet metal components to wood

Long-Life Lap Tek

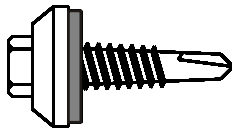

- #1/4-14 x 7/8" long, Plain or Painted

1/4" x 7/8" SD Ultimate® Lap Tek Screw

5/16" HWH Zinc Alloy Head w/ washer
For sheet metal joining

Long-Life HWH Wd Screw

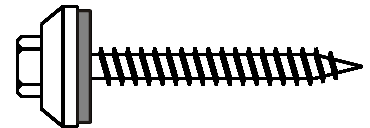

- #10-14 x 1" long, Plain or Painted
- #10-14 x 1-1/2" long, Plain or Painted
- #10-14 x 2" long, Plain or Painted
- #10-14 x 2-1/2" long, Plain or Painted

#10-14 Ultimate® Wood Screw

5/16" HWH Zinc Alloy Head w/ washer
To attach sheet metal components to wood



ML150 Panel Accessories Guide

HWH Self-Drilling Screw

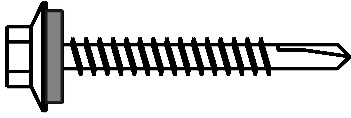

- #12-14 x 1" long, Plain or Painted
- #12-14 x 1-1/4" long, Plain or Painted
- #12-14 x 1-1/2" long, Plain or Painted
- #12-14 x 2-1/2" long, Plain or Painted

#12-14 Drill Point #2 (DP2)
5/16" HWH w/ washer, Zinc Coated
To attach sheet metal components to steel

Long-Life HWH SD Screw

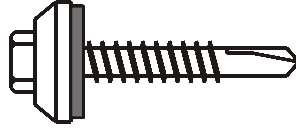

- #12-14 x 1-1/4" long, Plain or Painted

#12-14 Ultimate® Drill Point #2 (DP2) Screw
5/16" HWH Zinc Alloy Head w/ washer
To attach sheet metal components to steel

HWH Self-Drilling Screw



- #12-14 x 1" long, Plain
- #12-14 x 1-1/2" long, Plain

#12-14 Drill Point #2 (DP2) Screw
5/16" HWH (No Washer), Zinc Coated
For attachment of structural members to steel

Pipe Boot

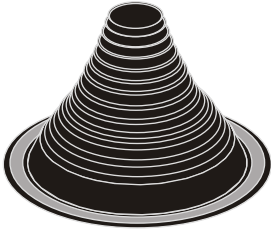

- #3 Boot - Fits 1/4" to 5" diameter (8" base)
- #4 Boot - Fits 3" to 6" diameter (9-1/2" base)
- #5 Boot - Fits 4" to 7" diameter (11" base)
- #6 Boot - Fits 5" to 9" diameter (12-3/4" base)

Pipe Boot, Black EPDM
For use with pipe penetrations

High Temp. Pipe Boot

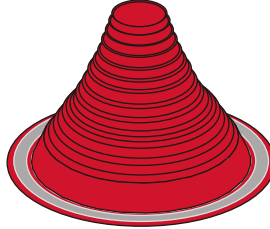

- #3 Boot - Fits 1/4" to 5" diameter (8" base)
- #4 Boot - Fits 3" to 6" diameter (9-1/2" base)
- #5 Boot - Fits 4" to 7" diameter (11" base)
- #6 Boot - Fits 5" to 9" diameter (12-3/4" base)

High Temp. Pipe Boot, Orange Silicone
For high temperature pipe penetrations

Retrofit Pipe Boot

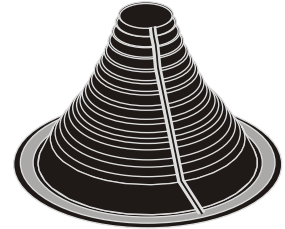

- #1 Boot - Fits 3/4" to 2-3/4" diameter
- #2 Boot - Fits 2" to 7-1/4" diameter
- #3 Boot - Fits 3-1/4" to 10" diameter

Retrofit Pipe Boot, Black EPDM
For use with "wrap-around" applications

Gutter Hanger

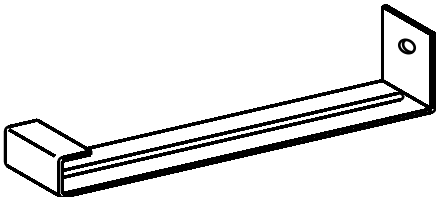

- 5" Hidden Gutter Hanger
- 6" Hidden Gutter Hanger
- 7" Hidden Gutter Hanger
- 8" Hidden Gutter Hanger

Hidden Gutter Hanger, 18 ga. Galvanized
For use with GT## gutter profiles

Gutter End Cap

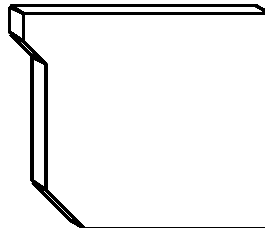

- 5" End Cap, Left and Right
- 6" End Cap, Left and Right
- 7" End Cap, Left and Right
- 8" End Cap, Left and Right

Gutter End Caps (match gutter material)
For use with GT## gutter profiles

Outlet Tube

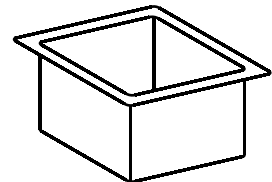

- 3" x 4"
- 4" x 5"
- Custom Size: _____

Downspout Outlet Tube (match gutter matl.)
For use with rectangular downspouts