

Advantage-Lok® Advantage-Lok II

Installation Manual



PO Box 229
Fayetteville, NC 28302

• www.unionmetalroofing.com •

Toll-Free
(888) MTL-ROOF



IMPORTANT NOTICE

This manual contains suggestions and guidelines on how to install the subject Union Corrugating panels and trim details. The contents of this manual include the guidelines that were in effect at the time this publication was originally printed. In an effort to keep pace with the ever-changing code environment, Union Corrugating retains the right to change specifications and / or designs at any time without incurring any obligations. To insure you have the latest information available, please inquire or visit our web site. Application and design details are for illustrative purposes only and may not be appropriate for all environmental conditions and/or building designs. Projects should be engineered and installed to conform to applicable building codes, regulations, and accepted industry practices.



TABLE OF CONTENTS

Introduction, Design, & Testing - Advantage Lok	3
Introduction, Design, & Testing - Advantage Lok II	4
Tools, Equipment, and Safety.....	5
Delivery & Packaging Options	5
Storage & Handling	6-8
Foot Traffic	8
Field Cutting	9
Touch-Up Paint	9
Design & Installation Considerations	9-10
Accessories	11
Trim Profiles	12-14
General Installation Information	14
Panel Installation	15-17
Typical Conditions	18
Trim Installation & Details	19-29
Curb Detail	30-32

INTRODUCTION

The Advantage-Lok Standing Seam panel gives you the leak resistance and beauty of a traditional standing seam roof without the expense and installation difficulty of clips. The 5/8" long fastening slots allow the panel to easily expand and contract with temperature changes. The full 1-3/8" high rib provides for additional leak protection and wind uplift resistance, and a sharp, well-defined look. The Advantage-Lok Standing Seam panel is designed to be installed over a solid deck on roof pitches of 3 on 12 and greater. With proper handling and installation, your Advantage-Lok panels will provide years of leak-free performance and beauty. Please review this manual carefully and completely before beginning your installation.

Applications:

Advantage-Lok is an architectural (non-structural) panel that is ideal for light commercial and residential applications. It can be used for roofing, mansards, or fascias. The panels must be applied over a solid substrate. Green, wet and treated wood should not be used in direct contact with any Advantage-Lok panels.

Available Specifications:

Colors and Finishes:

The Advantage-Lok panel is available in 26 ga. prepainted steel. It is also available in 26 ga. acrylic coated Galvalume®. Our siliconized polyester paint system and Galvalume® substrate are individually covered by a limited warranty. Please see our color chart for details on our paint system. Warranty copies are available upon request.

Widths:

The Advantage-Lok panel is available in 16" coverage width in 26 ga. The 1/16" striations provide strength and reduce the incidence of oil canning in the panel.

Lengths:

The Advantage-Lok Panel is available in standard lengths from 3' to 40'. Longer lengths require additional handling, packaging, and shipping considerations. An extra handling charge may apply to panels over 40'. Please consult your local Union Corrugating office for recommendations. Advantage-Lok panels cannot be end lapped. You must order full length panels to avoid end laps.

Rib Height:

The full 1-3/8" high rib provides for improved leak resistance over other typical panels. Some prefer this higher rib for the finished look it presents.

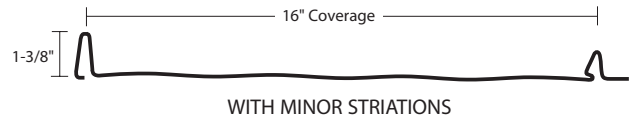

DESIGN

This manual contains suggestions and guidelines on how to install Advantage-Lok panels. The installation details shown are proven methods of construction, but are not intended to cover all instances, building requirements, designs, or codes. It is the responsibility of the designer/installer to ensure that the details meet particular building requirements. The designer /installer must be aware of , and allow for, expansion/ contraction of roof panels. The details may require changes or revisions due to each project's conditions.

There are certain minimum wind loads and snow loads that a roof must generally be designed to support. Consult local building officials to determine the appropriate building design load requirements. A professional engineer should be consulted for all roof system designs. It is the buyer's responsibility to verify all applicable code requirements, check all measurements, and determine suitability of product for job. Any job estimates or take-offs provided by Union Corrugating are for reference only. The buyer is responsible for verifying actual length and quantities needed. Implied warranties of merchantability and fitness for a particular purpose are disclaimed. All Advantage-Lok instructions assume that a qualified firm or individual has been contacted regarding applications of this product. Failure to comply with stated recommendations relieves the manufacturer of responsibility for any damage or deterioration of the product incurred and voids any applicable warranty.

TESTING

Miami-Dade County Approval NOA# 08.0402.10

ASCE 7-98 Compliant

Florida Building Code Approval #FL9610.2

Texas Department of Insurance RC-118

UL 790 Fire Class A and UL 2218 Impact Class 4

UL 580 Uplift (UL90 Classification Construction #529)

INTRODUCTION

The Advantage-Lok II Standing Seam panel gives you the leak resistance and beauty of a traditional standing seam roof without the expense and installation difficulty of clips. The full 1" high rib provides for additional leak protection and wind uplift resistance, and a sharp, well-defined look. The Advantage-Lok II Standing Seam panel is designed to be installed over a solid deck on roof pitches of 3 on 12 and greater. With proper handling and installation, your Advantage-Lok II panels will provide years of leak-free performance and beauty. Please review this manual carefully and completely before beginning your installation.

Applications:

Advantage-Lok II is an architectural (non-structural) panel that is ideal for light commercial and residential applications. It can be used for roofing, mansards, or fascias. The panels must be applied over a solid substrate. Green, wet and treated wood should not be used in direct contact with any Advantage-Lok II panels.

Available Specifications:

Colors and Finishes:

The Advantage-Lok II panel is available in 26 ga. prepainted steel. It is also available in 26 ga. acrylic coated Galvalume®. Our siliconized polyester paint system and Galvalume® substrate are individually covered by a limited warranty. Please see our color chart for details on our paint system. Warranty copies are available upon request.

Widths:

The Advantage-Lok II panel is available in 16" coverage width in 26 ga. The 1/16" striations provide strength and reduce the incidence of oil canning in the panel.

Lengths:

The Advantage-Lok II Panel is available in standard lengths from 3' to 40'. Longer lengths require additional handling, packaging, and shipping considerations. An extra handling charge may apply to panels over 40'. Please consult your local Union Corrugating office for recommendations. Advantage-Lok II panels cannot be end lapped. You must order full length panels to avoid end laps.

Rib Height:

The full 1" high rib provides for improved leak resistance over other typical panels.

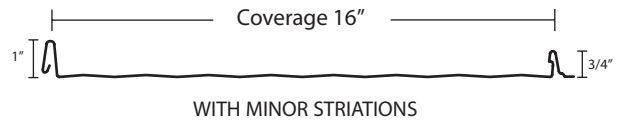

DESIGN

This manual contains suggestions and guidelines on how to install Advantage-Lok II panels. The installation details shown are proven methods of construction, but are not intended to cover all instances, building requirements, designs, or codes. It is the responsibility of the designer/installer to ensure that the details meet particular building requirements. The designer/installer must be aware of , and allow for, expansion/contraction of roof panels. The details may require changes or revisions due to each project's conditions.

There are certain minimum wind loads and snow loads that a roof must generally be designed to support. Consult local building officials to determine the appropriate building design load requirements. A professional engineer should be consulted for all roof system designs. It is the buyer's responsibility to verify all applicable code requirements, check all measurements, and determine suitability of product for job. Any job estimates or take-offs provided by Union Corrugating are for reference only. The buyer is responsible for verifying actual length and quantities needed. Implied warranties of merchantability and fitness for a particular purpose are disclaimed. All Advantage-Lok II instructions assume that a qualified firm or individual has been contacted regarding applications of this product. Failure to comply with stated recommendations relieves the manufacturer of responsibility for any damage or deterioration of the product incurred and voids any applicable warranty.

TESTING

Miami-Dade County Approval NOA# 06-1002.15
 Florida Building Code Approval #FL9610.3
 UL 790 Fire Class A
 UL 2218 Impact Class 4
 UL 580 Uplift

TOOLS & EQUIPMENT

- Cordless Screw Gun
- Snips
- Tape Measure
- Electric Metal Shear *
- Caulk Gun
- Pop Rivet Tool
- Chalk Line
- "Duckbill" Locking Pliers
- Hemming Tool
- Electrical Extention Cord #14

* We do not recommend the use of a circular saw.

Use of a power saw could increase the probability of edge rust. Metal shavings on the panel surface could damage the panel finish.

Installer must have prior experience and knowledge of the listed tools and their uses in working with metal roofing.

SAFETY

If you must walk on a metal roof, take great care. Metal panels can become slippery, so always wear shoes with non-slip soles. Avoid working on metal roofs during wet conditions when the panels can become extremely slippery. Walking or standing on a metal roof which does not have a plywood or other deck beneath it is not recommended. However, if you must do so, always walk on the purlins, never between.

OSHA safety regulations should be complied with at all times.

⚠ CAUTION ⚠

Always wear heavy gloves when working with steel panels to avoid cuts from sharpe edges. When power cutting or drilling steel panels, always wear safety glasses to prevent eye injury from flying metal fragments.

DELIVERY & PACKAGING OPTIONS

Lead Time:

Please allow 14 days for delivery for standard colors. Any special requests or non-standard colors may require longer lead times. Consult your local Union Corrugating sales representative for special requests.

Packaging:

A packaging charge will be added to all orders. Standard packaging is crating for all orders.

For LTL and overseas shipments, panels are packaged in a completely enclosed crate to provide optimum protection. Additional charges will apply for non-standard packaging and special requests..

Standard Packaging

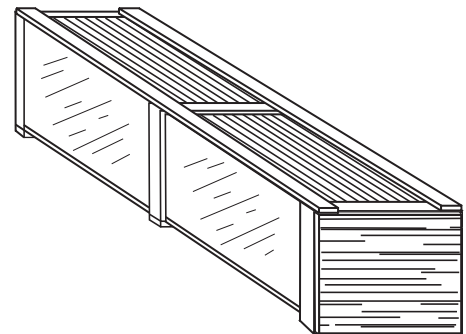

Optional Packaging

Full Crate - This method is utilized for all LTL and overseas shipments or at customer's request, for an additional charge.

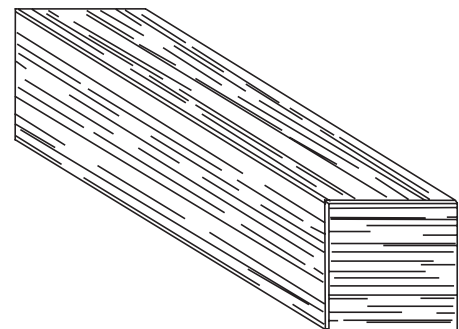

STORAGE & HANDLING

Storage:

Bare Galvalume and painted panels can be expected to give many years of rust-free service when precautions are taken during storage.

If metal is not to be used immediately, store inside in a well-ventilated, dry location. **Any outdoor storage is at the customer's own risk!** At time of delivery, inspect panels for moisture. If moisture has formed, the panels should be uncrated, wiped dry, and allowed to dry completely. Failure to remove the entrapped moisture between the sheets immediately will affect the service life of the metal. Extended storage of panels in a bundle is not recommended. Under no circumstances should the sheets be stored near or come in contact with salt water, corrosive chemicals, ash, or fumes generated or released inside the building of nearby plants, foundries, plating works, kilns, fertilizer, and wet or green lumber.

If panel bundles must be stored outside, the following list of requirements must be adhered to:

1. The storage area should be reasonably level, and should be located so as to minimize handling of crates during the construction process.
2. When stored on bare ground, place a plastic ground cover under the crates to minimize condensation on the panels from moisture in the soil.
3. Store crates at least 6 inches above the ground level to allow air circulation beneath the bundle, and to prevent rising water from entering the bundle.
4. Elevate one end of the crate slightly to permit runoff of moisture from the top of the bundle or from between nested panels. A water-resistant cover, like canvas, should be placed over the crates, with allowance for air circulation under the cover. The cover should be blocked off of the crate. (see Figure 1)

Any outdoor storage of panels is at the customer's own risk!

Fig. 1

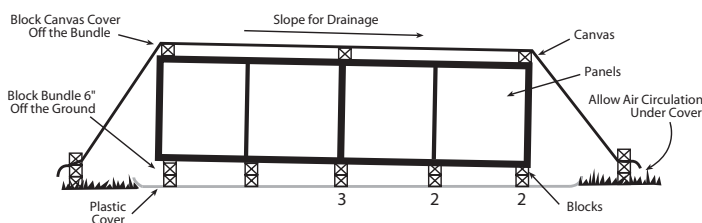

5. Inspect stored crates daily and repair any tears or punctures in the water-resistant cover with a compatible waterproof tape.
6. Re-cover opened crates at the end of each day to prevent entry of moisture and exposure to sunlight.

Polyfilm Removal:

The panels may have a protective polyfilm layer applied to the topside of the panel to prevent possible damage to the painted surface. If panel has a protective polyfilm coating, remove the polyfilm before exposing to direct sunlight and high temperatures. After exposure to sunlight, the polyfilm cannot be removed. Under no circumstances should the polyfilm remain on the panels after installation. Union Corrugating bears no responsibility for damage to metal caused by improper storage and failure to remove polyfilm.

Storage on Roof:

To facilitate the handling of Advantage-Lok panels, panel crates can be lifted and placed on the roof. Crates need to be placed parallel to the framing members and the slope of the roof. Load capabilities of the structure must be checked prior to placing crates on the roof.

When lifting packaged sheets, make sure they are adequately supported. Panels less than 20' in length can normally be lifted with a forklift; however, when lifting panels in excess of 20', it is recommended that a spreader bar and slings be used. When lifting, no more than 1/3 of the length of the panel should be left unsupported.

Make a plan for bundle placement determining how much area a bundle of panels will cover. Bundles should be placed on the roof in accordance with the direction the panel will be installed. Consider where the string line, if any, is to run at the eave to set roof panels by. Roof bundles should not interfere with this string line. (see Figure 2)

Fig. 2

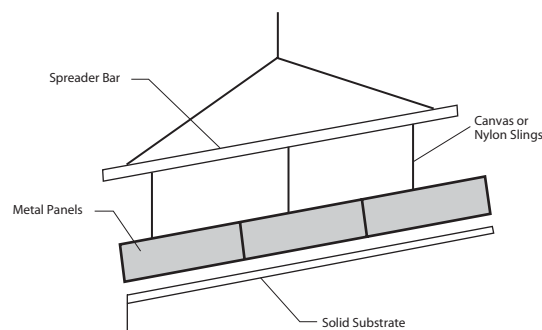

STORAGE & HANDLING

Receiving Materials:

It is the responsibility of the installer to unload material from the delivery truck. The installer shall be responsible for providing suitable equipment for unloading of material from the delivery truck.

After receiving material, check the condition of the material, and review the shipment against the shipping list to ensure all materials are accounted for. If damages or shortages are discovered, it should be noted on the shipping copy at time of delivery. If material is delivered by common carrier, a claim must be made with the carrier as soon as possible. If replacement material is required, you must contact Union Corrugating to place the order. If material is delivered on company trucks, note the damages and shortages on the shipping copy. Any damages and shortages must be reported to Union Corrugating within 48 hours from the time of shipment.

5. After crates are opened, individual panels must also be handled carefully to prevent panel buckling or damage to the panel coating. When removing a panel from a crate, it should never be allowed to slide over another panel. The individual panels should be "rolled" out of the crate in order to minimize the chance of panel damage.
6. Soft gloves must be worn when handling panels.

Manual Handling:

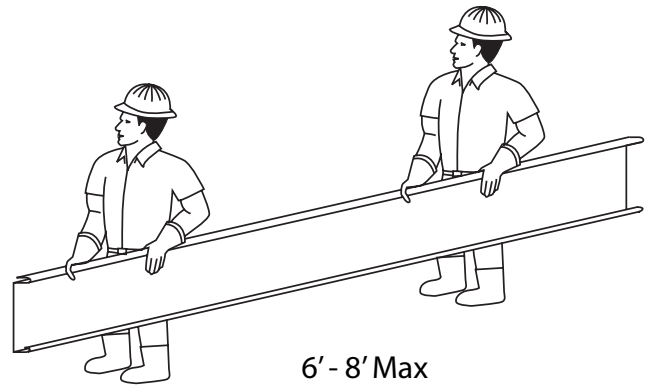

⚠ CAUTION ⚠

Improper loading and unloading of crates may result in bodily harm and/or material damage. Union Corrugating is not responsible for bodily injuries and/or material damages resulting from improper loading and unloading.

General Handling:

Each crate should be handled carefully to avoid being damaged. Care should be taken to prevent bending of the panel or abrasion to finish. Please follow these steps for proper care while unloading and handling crates in order to prevent panel damage:

1. Crates should remain intact during any handling, and until the individual panels in each bundle are ready to be installed. Crates should never be lifted by the banding.
2. Lift each crate as close as possible to its center of gravity.
3. If the crates are to be lifted with a crane, use a spreader bar of appropriate length, and nylon band slings. (Do not use wire rope slings as they will damage the panels)
4. Depending on panel length, some crates may be lifted by a forklift. When using a forklift, the forks should be spread apart to their maximum spacing, and the load must be centered on the forks to prevent scratching the next panel. A panel should never be picked up by its ends. Instead, lift the panel along its longitudinal edge and carry in a vertical (not flat) position. For panels over 10 feet long, two or more people should lift the panel along the same edge.

Incorrect

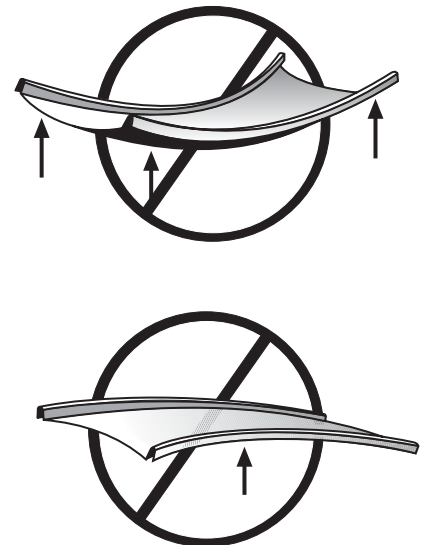

Mechanical Handling:

Forklift

A forklift may be used for panels up to 20' long. Please make sure the forks are at their maximum separation. Do not transport open crates. When transporting crates across rough terrain, or for a long distance, some means of supporting the panel load must be used.

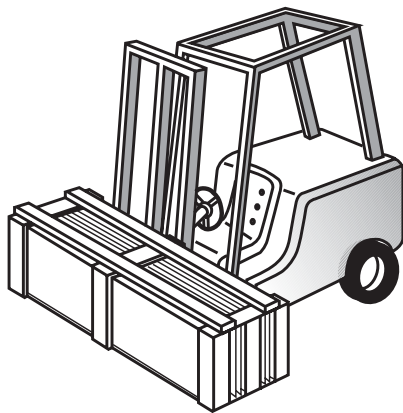

Crane

A crane should be used when lifting panels with lengths greater than 20'. Please be sure to utilize a spreader bar to ensure the even distribution of the weight to the pick up points. As a rule, when lifting panels, no more than 1/3 of the length of the panel should be left unsupported. Canvas or nylon slings should be used to pick up panels. DO NOT use cable or chains because this will damage the panels.

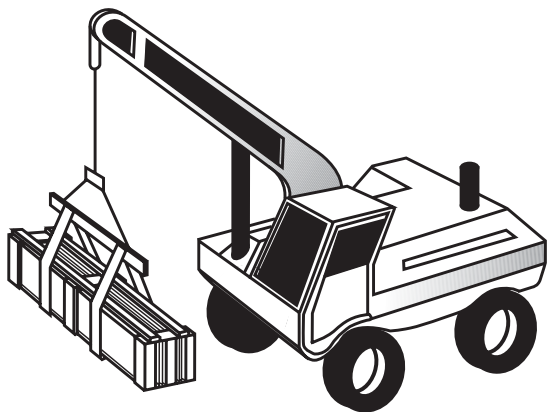

FOOT TRAFFIC

Foot traffic can cause distortion of panel and damage to finish. Traffic over the installed system must be kept to an absolute minimum. If continuous foot traffic is necessary for maintenance over certain areas of the roof, then a permanent walkway should be installed.

If continuous foot traffic is necessary during installation, provide walking platforms to avoid any panel damage as shown below:

When walking on the roof panels is unavoidable, walk only in the flats of the panel as shown below. Walking on the ribs can cause damage to the panels.

CAUTION

All applicable safety regulations, including OSHA regulations, must be complied with during the panel installation process.

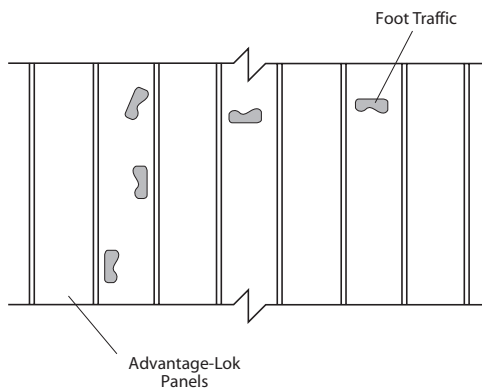
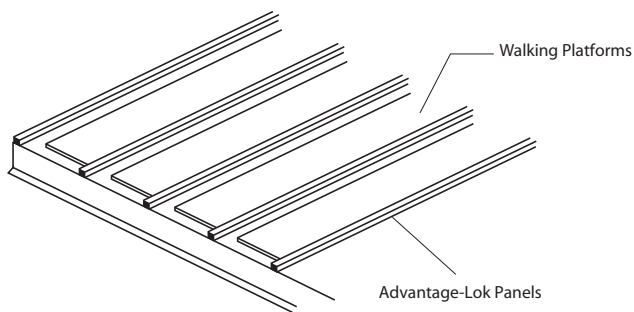

FIELD CUTTING

Tin snips or a “nibbler” type electric tool are recommended for field cutting Advantage-Lok panels. If a skill saw is used, the blade will generate slivers of metal chips. Any slivers of metal chips must be immediately removed from the Advantage-Lok panels because they will damage the finish and shorten the life of the product.

One method of preventing this problem is to flip the panels over when cutting. This allows the slivers of metal chips to be brushed from the back side and avoids damaging the paint on the top side of the panels.

⚠ CAUTION ⚠

All product surfaces should be free of debris at all times. Installed surfaces should be wiped clean at the end of each work period. Never cut panels over metal surfaces. Metal shavings will rust on the surface thus voiding the warranty.

⚠ CAUTION ⚠

When cutting metal panels, goggles must be worn for eye protection.

TOUCH-UP PAINT

All painted panels and flashings have a factory applied baked on finish. Handling and installing panels may result in some small scratches or nicks to the paint finish. Touch-up paint is available in matching colors. It is recommended that a small brush be used to apply touch-up paint to those areas that are in need of repair. Touch-up paint does not have the superior chalk and fade resistance of the factory applied paint finish and will normally discolor at an accelerated rate. Aerosol paint should not be used because of the overspray that may occur. Periodic touch-up may be required to maintain color match. There is no warranty on touch-up paint in regards to colormatch because the paint processes are different.



Touch-Up Paint

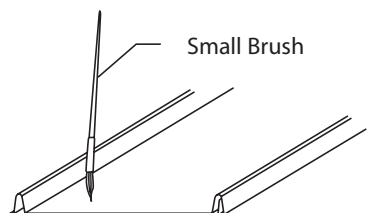

DESIGN CONSIDERATIONS & CALCULATIONS

Insulation & Ventilation:

Proper design and installation of vapor barriers and ventilation systems are important to prevent condensation and the resulting problems of moisture damage and loss of insulation efficiency.

Condensation occurs when moisture-laden air comes in contact with a surface temperature equal to or below the dew point of the air. This phenomenon creates problems that are not unique with metal buildings; these problems are common to all types of construction.

In addition to providing resistance to heat transfer, insulation can also protect against condensation forming on cold surfaces, either inside the building or within the wall/roof system cavity. The arrangement of the building’s insulation system and vapor retarder is the responsibility of the building designer. These are some basic guidelines to help control condensation in a metal building:

1. The insulation should have a vapor retarder face on the “warm” side of the insulation. For most buildings, this means that the vapor retarder is on the inside surface. (toward the building’s interior)
2. The thickness of the insulation must be designed to maintain the temperature of the vapor retarder above the interior dew point, using the worst-case expected outside temperature.
3. All perimeter conditions, seams, and penetrations of the vapor retarder must be adequately sealed in order to provide a continuous membrane to resist the passage of water vapor.
4. Building ventilation, whether by gravity ridge vent, power operated fans, or other means, contributes significantly to reduce condensation. The movement of air to the outside of the building reduces the interior level of vapor pressure.

On buildings that have an attic space or are being retrofitted with a metal roofing system, vents should be placed at both ends of the eave and peak of the roof in order to prevent a buildup of moisture (humidity) in the attic space.

Contact your local building code officials or an engineer on proper ventilation practices for your area.

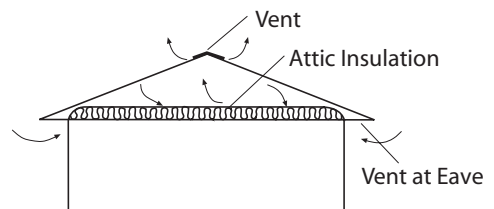

DESIGN/INSTALLATION CONSIDERATIONS

Substrates:

Warm Weather Note: In warm weather and tropical climates, Union **REPEL** synthetic underlayment should be used over the existing substrate. The high temperature resistance of **REPEL** prevents it from sticking to the panels and tearing, which can occur with asphalt-based felt paper.

Cold Weather Note: In cold weather climates, it is recommended that you use and Ice and Water Shield at the valley and eave. This needs to be applied over the substrate before the **REPEL** synthetic underlayment is installed.

⚠ CAUTION ⚠
 Extreme caution should be used when applying these products because they can be slippery.

Roof Pitch Factor Chart:

This chart should be used when specifying and ordering Advantage-Lok Panels and Trims.

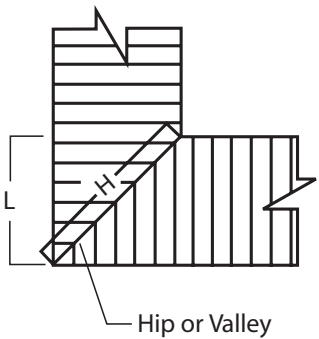

$(L) \times (\text{Hip Valley Multiplier}) = H$

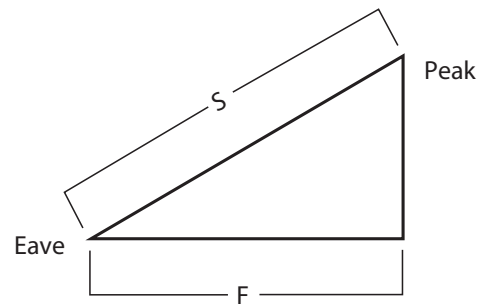

$(F) \times (\text{Pitch Factor}) = S$

PITCH	PITCH FACTOR	HIP/VALLEY MULTIPLIER	PITCH	PITCH FACTOR	HIP/VALLEY MULTIPLIER
3:12	1.0308	1.4362	8:12	1.2019	1.5635
4:12	1.0541	1.4530	9:12	1.2500	1.6008
5:12	1.0833	1.4743	10:12	1.3017	1.6415
6:12	1.1180	1.5000	11:12	1.3566	1.6853
7:12	1.1577	1.5298	12:12	1.4142	1.7320

ACCESSORIES

* Unless otherwise noted, accessories and trim are compatible with both Advantage-Lok and Advantage-Lok II



Pop Rivet (stainless)
cccSSPR.125
(1/8" x 3/16")



#14 x 7/8" Hex Head Lap Tek Screw
Metal-to-Metal Connection
GLTEK



#9 x 1-1/2" Hex Head Woodmate Screw
Metal-to-Wood Connection
cccWS150



#10 x 1" Pancake Head Woodscrew
GPHWS100250

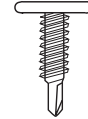

1" Pancake Head Tek Screw
GPHDS100250

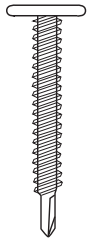

2-1/2" Pancake Head Tek Screw
GPHWS250250

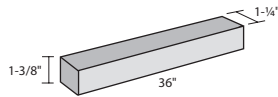

Neoprene Universal Closure
RCALUNIVERSAL
(Use on Advantage-Lok)

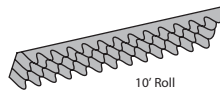

Versavent Universal Closure
VRCUNIVERSAL
(Use on Advantage-Lok II)

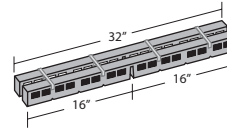

Vented Closure Strip
VRCAL16

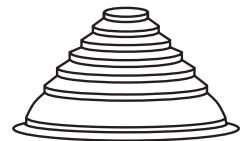

Pipe Boot
MF3
(Various sized, heat treated & retro fit also available)

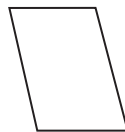

26ga Flat Sheet
cccGPFS26415120
(41-9/16" x 10')



29ga Flat Sheet
cccPFS29415120
(41-1/4" x 10')

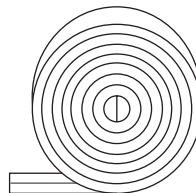

Double Bead Butyl Tape
DBBTLST
(7/8" x 3/16" x 40')

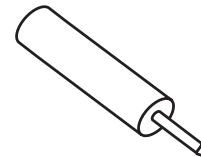

Urethane Tube Sealant
TUBESEALANT
(10.3 oz)

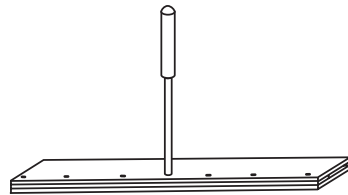

Hemming Tool
HEMMINGTOOL19
(1/8" Opening)



Touch Up Paint w/ Brush
cccPAINTTUP.6OZ
(.6 oz)

<p>FLUSH EAVE</p> <p>ITEM # - cccALSE</p> <p>Blank Width 8-1/4"</p> <p>Specify Pitch 12</p>	<p>SQUARE EAVE/RAKE</p> <p>ITEM # - cccALSQE</p> <p>Blank Width 8-1/2"</p>	<p>PLUMB EAVE</p> <p>ITEM # - cccALPE</p> <p>Blank Width 8-1/2"</p> <p>Specify Pitch 12</p>	<p>COUNTER FLASHING</p> <p>ITEM # - cccALCF</p> <p>Blank Width 4.35"</p>
<p>AD-LOK Z-CLOSURE</p> <p>ITEM # - cccALZC</p> <p>Blank Width 3-3/8"</p>	<p>AD-LOK II Z-CLOSURE</p> <p>ITEM # - cccALKCZ</p> <p>Blank Width 3"</p>	<p>BOX GUTTER</p> <p>ITEM # - cccALBG</p> <p>Blank Width 20-5/8"</p> <p>Specify Pitch 12</p>	<p>BOX GUTTER END</p> <p>ITEM # - cccALBGE (Specify left or right)</p> <p>Blank Width 8-1/2" x 7-1/4"</p>
<p>GUTTER HANGER</p> <p>ITEM # - cccALHGH6</p> <p>Blank Width 6"</p>	<p>ELBOW</p> <p>ITEM # - cccALELBOW</p> <p>Blank Width 15-3/4"</p> <p>Specify seam location: front, back, left or right. Available in 45° and 95°. Also available unnotched.</p>	<p>DOWNSPOUT WALL BRACKET</p> <p>ITEM # - cccALDWB (26 ga only)</p>	<p>OUTLET TUBE</p> <p>ITEM # - cccA3X4OT</p>
<p>ELBOW</p> <p>ITEM # - cccALDOWNSPOUT (Also available unnotched)</p> <p>Blank Width 15-3/4"</p>	<p>GUTTER MITERED CORNERS</p> <p>ITEM # - cccGALGUTROM26 (Outside Corner)</p> <p>ITEM # - cccGALGUTRIM26 (Inside Corner)</p> <p>*Use with eave gutter and hang-on gutter *Specify inside or outside</p>	<p>GUTTER SPLICE</p> <p>ITEM # - cccALGS</p> <p>Specify Pitch 12</p>	

All Trim Available in 10' Lengths. All open hems are designed to work with the Z-Closure. C = Colored side.

VALLEY

ITEM # - ccc20PV
(Also available without hems)

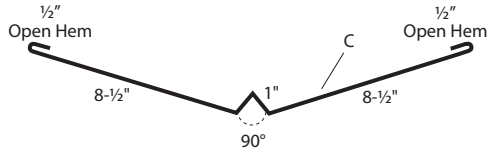

Blank Width 20"



PITCH CHANGE

ITEM # - cccALTF

Note:
When the pitch difference between roofs is 2/12 or less, a custom trim must be used.

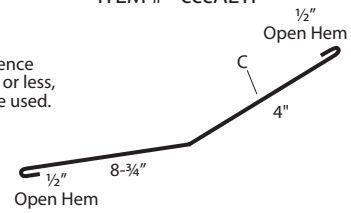

Blank Width 13-3/4"

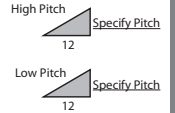

BOX RAKE

ITEM # - cccALRAKE

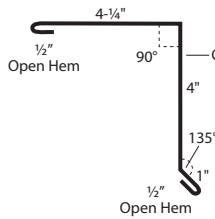

Blank Width 10-1/4"

END WALL

ITEM # - cccALEWF

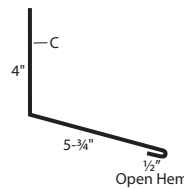

Blank Width 10-1/4"

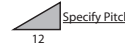

SIDE WALL

ITEM # - cccALSW

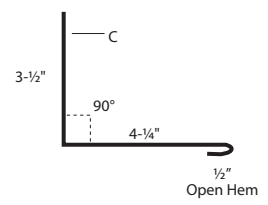

Blank Width 8-1/4"

FLAT HIP

ITEM # - cccALFH



Blank Width 13-3/4"



STEP HIP

ITEM # - cccALSH

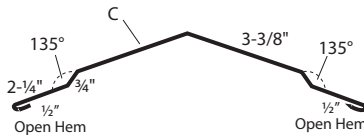

Blank Width 13-3/4"



VENT RETAINER

ITEM # - ALVR

Note:
Normally not painted; Galvanized or Galvalume

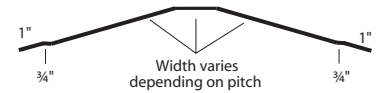

Blank Width and Dimensions vary according to pitch



FLAT RIDGE

ITEM # - cccALFR



Blank Width 13-3/4"



STEP RIDGE

ITEM # - cccALSRC

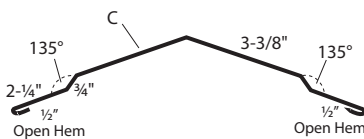

Blank Width 13-3/4"



SINGLE SLOPE RIDGE

ITEM # - cccALSSR

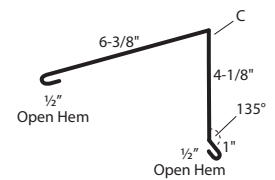

Blank Width 12-1/2"



CLEAT

ITEM # - cccALCLEAT

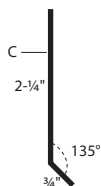

Blank Width 3"

OFFSET CLEAT

ITEM # - cccALOSCLEAT

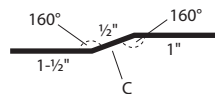

Blank Width 3"

1.5" SILL/HEAD

ITEM # - cccALSILLHEAD

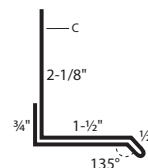

Blank Width 6-7/8"

SILL TO SOFFIT

ITEM # - cccALSOFT

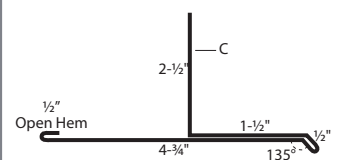

Blank Width 10-1/4"

All Trim Available in 10' Lengths. All open hems are designed to work with the Z-Closure. C = Colored side.

CUSTOM TRIM

All trim dimensions and profiles shown in this manual can be modified to meet specific custom projects. For a quote on custom dimensions, change the dimensions on our current drawings to meet your requirements and fax it to your sales representative. For a quote on a custom designed trim profile not shown in this manual, please provide your sales representative with a sketch and include the required dimensions.

An example of a simple sketch is shown here.

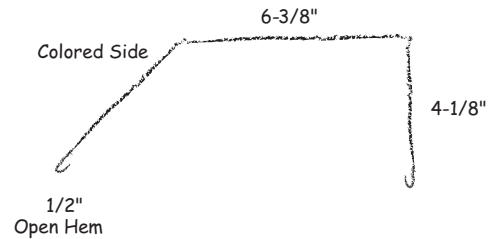

GENERAL INSTALLATION INFORMATION

The installer should be familiar with all installation instructions before starting work. Before beginning installation of panels, the installer should examine the substrate or framing to ensure that all supporting members are straight, level, and plumb to avoid any panel distortion. All substructures should be designed to meet all necessary code requirements.

The panels should be installed plumb, straight, and square to the leave. Some field cutting and fitting of panels and trims is to be expected by the installer and minor field corrections are a part of normal installation work.

Installation procedures and penetrations by fasteners in the panel system shall be in accordance with the panel manufacturer's printed instructions. Trim shall be installed true, and in proper alignment with the panels.

Sealants must be field applied on dry, clean surfaces, as they apply to each trim application.

All trims, closures, and accessories shown on the installation drawings are available from Union Corrugating unless noted otherwise.

Oil canning in the flat area of the panels is common to the industry and does not affect the integrity of the panel. Therefore, oil canning is not a reason for rejection.

It is the responsibility of the installer to insure a suitable substrate prior to the application of Advantage-Lok. Distortion in the panel caused by handling, an uneven substrate, ripples or laps in the vapor barrier, construction debris, or extreme temperature changes are not a cause for rejection of material.

Condition of Substructure

Panel distortion may occur if not applied over properly aligned and uniform substructure.

The installer should check the roof deck for squareness before installing Advantage-Lok panels. Several methods can be used to verify squareness of the structure for proper installation of the panels.

Method A :

One method for checking the roof for squareness is to measure diagonally across one slope of the roof from similar points at the ridge and eave and obtain the same dimension.

Method B :

The 3-4-5 triangle system may also be used. To use this system, measure a point from the corner along the edge of the roof at a multiple of three (3). Measure a point from the same corner along another edge at a multiple of four (4). Then, by measuring diagonally between the two points established, the dimension should be exactly a multiple of five (5) to have a square corner. Multiple uses of this system may be required to determine building squareness. If the endwall cannot be made square, the roof system cannot be installed as shown in these instructions.

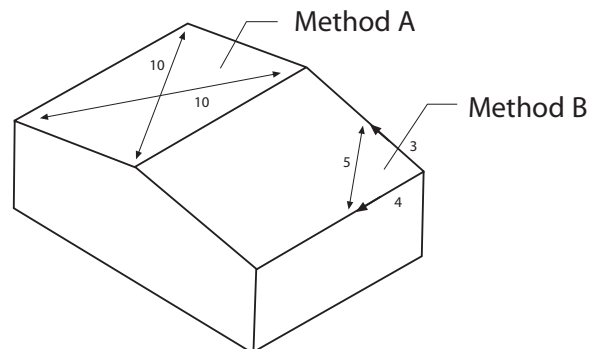

PANEL INSTALLATION

Advantage-Lok is an architectural concealed fastener panel. It is recommended that you use the concealed fastener method. There are fewer penetrations, better aesthetics, and more flexibility for thermal expansion. On continuous runs over 25' the concealed fastener method is required.

1. For best performance, we recommend using a synthetic roofing underlayment such as Union Repel over the roof deck or existing shingles. Repel provides additional water protection and will not tear or stick to the metal roofing like asphalt-based roofing felts.
2. Align the female edge of the first panel with a chalk line snapped from 0" to 1-3/4" at the rake edge. Panel should overhang eave a minimum of 1". (See Figure 1)
3. Hem panel following instructions on page 16. Square the panel to the eave and fasten with 1" pancake head wood-screws a maximum of 24" on center. Please refer to fastening guides on pages 30 & 31.

NOTE: To avoid panel distortion and to allow for maximum expansion and contraction of the panel, do not overdrive the pancake head woodscrews when fastening panels into the substrate.

4. To allow for movement of the panel towards the eave or ridge, place the fastener in the middle of the 5/8" slot. If you want the sheet to expand towards the eave, place the fastener at the bottom of the slot and pin the sheets at the ridge. If you want the sheet to expand towards the ridge place fastener at the top of the slot and pin sheets at eave.
5. Align the second panel female edge with the male edge of the starter panel. (See Figure 2) Panel edges must be flush with each other at eave edge. Remember, panels should be extended over eave by 1".
6. Lightly compress with palm of hand and snap panels together at seam. Snap panels from eave to ridge.
7. After panel seam is locked and flush at eave with 1st panel, fasten the panel with a 1" pancake head woodscrew along the male leg.
8. Continue to apply panels as in steps 2 thru 6.

Figure 1

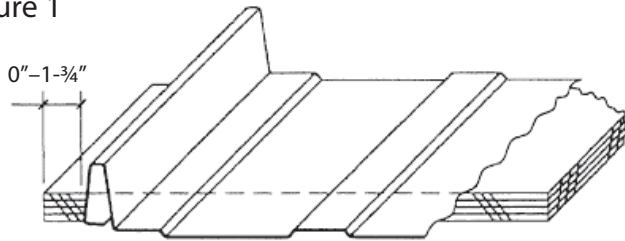
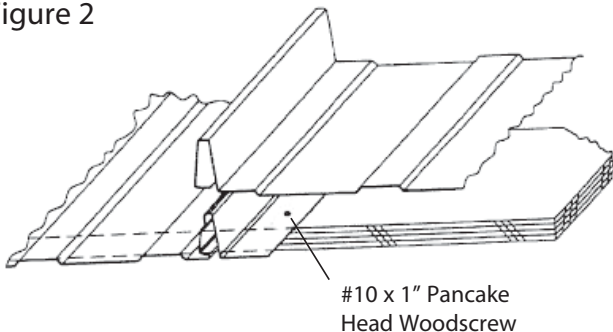

Figure 2



Advantage-Lok Fasteners Per Square

Spacing	16" Wide Panel
12"	90
16"	70
20"	55
24"	45

Advantage-Lok Conversion Factors

Squares to Lineal Ft.

$$\text{Squares} \times \text{Conversion Factor} = \text{LF}$$

EXAMPLE:

$$16'' \text{ Wide Panel} \\ 80 \times 75.15 = 6,012 \text{ LF}$$

FIELD HEMMING OF PANEL

Panel Eave End Field Hemming: When hemming panels, it works best to cut the ribs and hem the panel by turning the sheet upside down. For safety reasons, it is recommended that panels be hemmed on the ground.

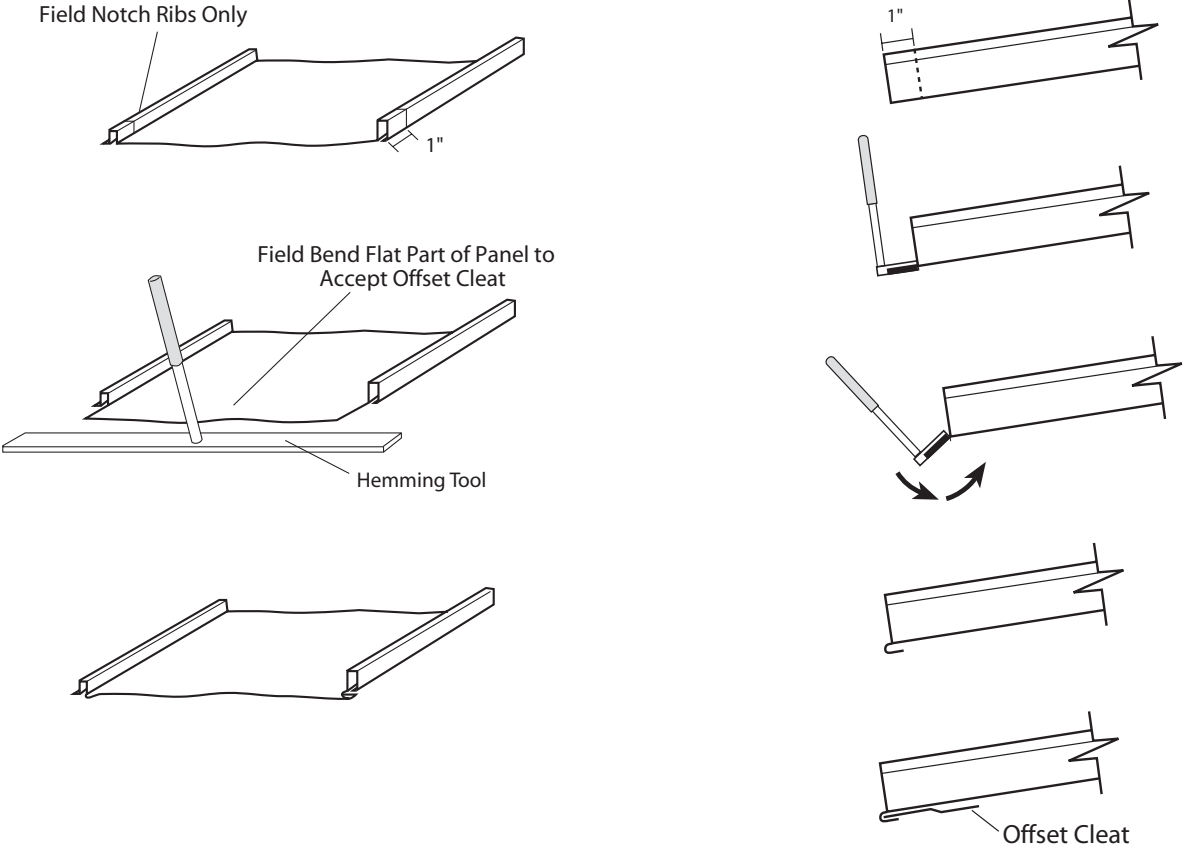

Square Rake Hemming Detail: Measure and hem side of panel based on distance from edge of Rake to rib. Bend side with the hemming tool.

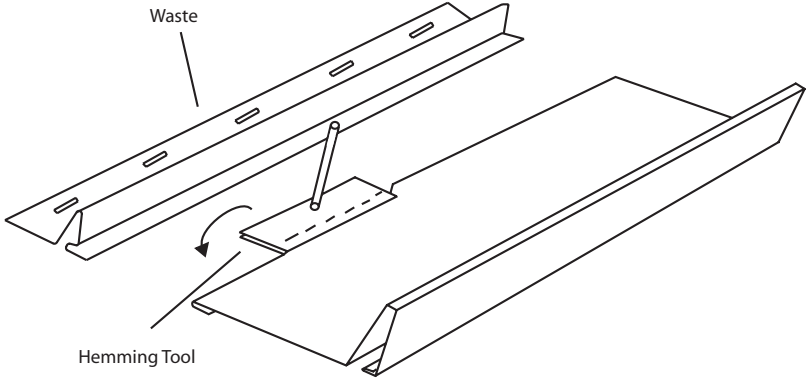

FIELD HEMMING OF PANEL

Metal panels at the eave and valley ends should be installed as shown in Figures 1 and 2. When using the offset cleat, you must order the panel a minimum of 1" longer to allow for field hemming of the panel.

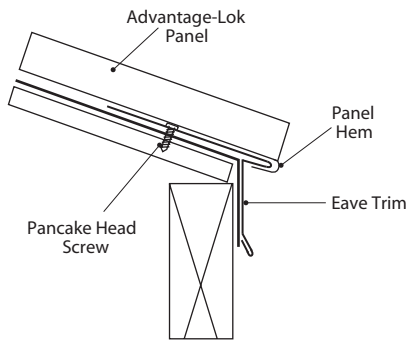

FIGURE 1
Eave

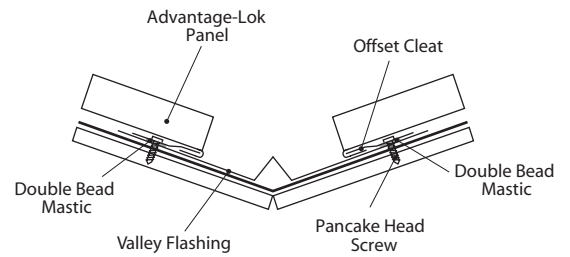
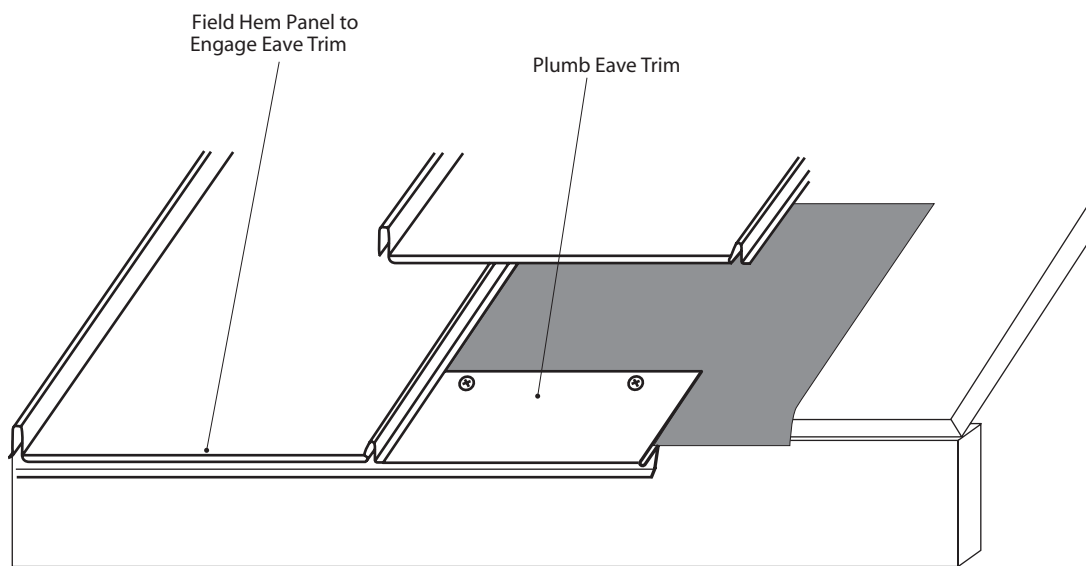
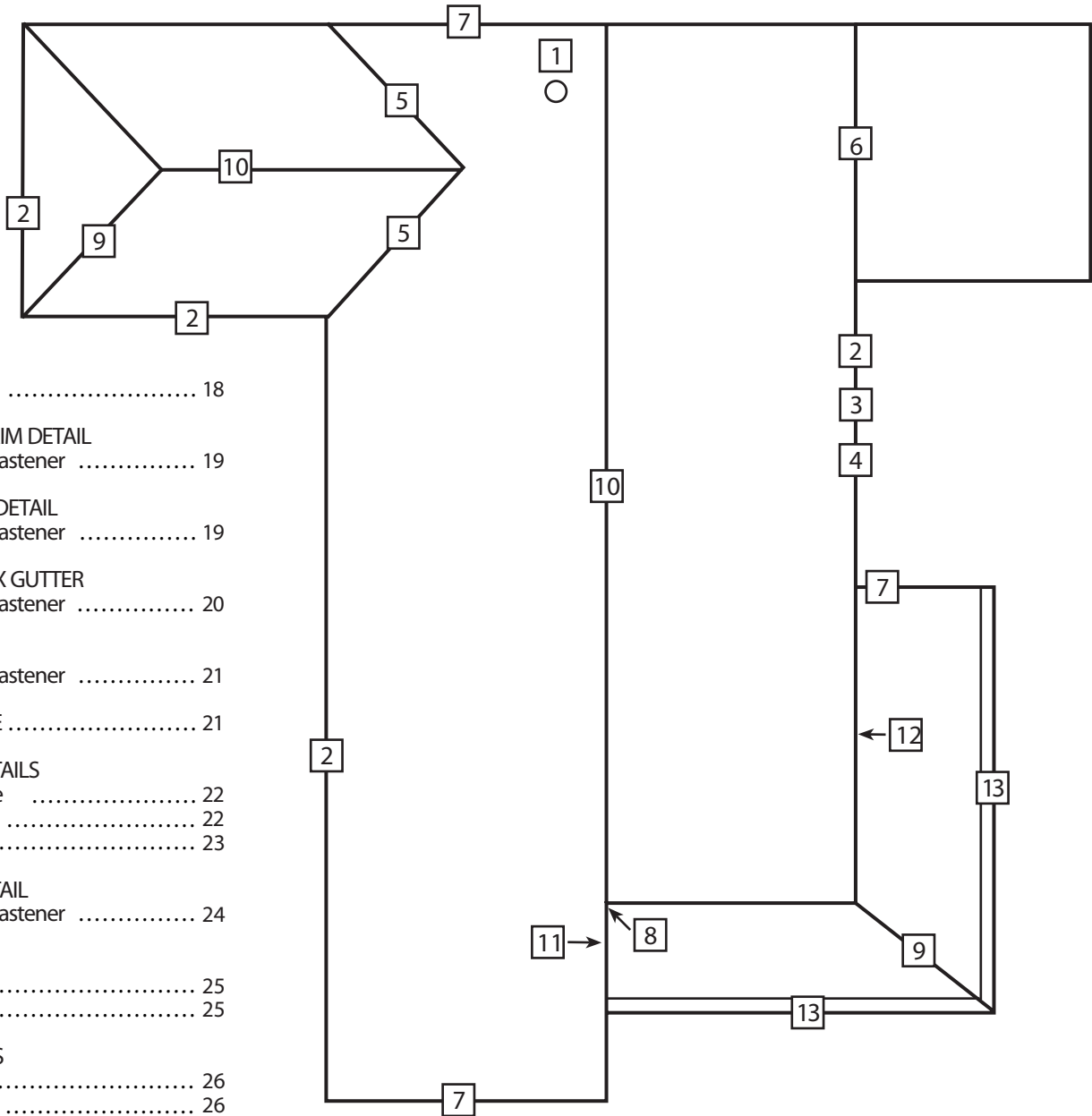

FIGURE 2
Valley



Plumb Eave Trim

TYPICAL CONDITIONS



1. PIPE FLASHING	18
2. FLUSH EAVE TRIM DETAIL	
A. Concealed Fastener	19
3. SQUARE EAVE DETAIL	
A. Concealed Fastener	19
4. EAVE WITH BOX GUTTER	
A. Concealed Fastener	20
5. VALLEY DETAIL	
A. Concealed Fastener	21
6. PITCH CHANGE	21
7. RAKE TRIM DETAILS	
A. Square Rake	22
B. Step Rake	22
C. Box Rake	23
8. SIDE WALL DETAIL	
A. Concealed Fastener	24
9. HIP DETAILS	
A. Hip	25
B. Step Hip	25
10. RIDGE DETAILS	
A. Flat Ridge	26
B. Step Ridge	26
11. SINGLE SLOPE RIDGE DETAILS	
A. Vented	27
B. Non Vented	27
12. END WALL DETAILS	
A. Vented	28
B. Non Vented	28
13. SILL DETAILS	
A. Sill	29
B. Sill to Soffit	29

FLUSH EAVE DETAIL

- Before installing panels, attach cleat to fascia with pancake head woods crews, 24" on center. Make sure the cleat will set in the open hem of the trim.
- Slide the Eave Trim over the cleat.
- Apply double bead mastic to the underside of the 1-1/2" leg of the offset cleat. Attach the cleat and the Eave trim to the deck with pancake head woodscrews. Allow the cleat to extend 1" over the eave.
- Hem the panel over the cleat. (Refer to pages 15 & 16 for details.)
- If 5K Gutter is to be installed, follow manufacturer's instructions.

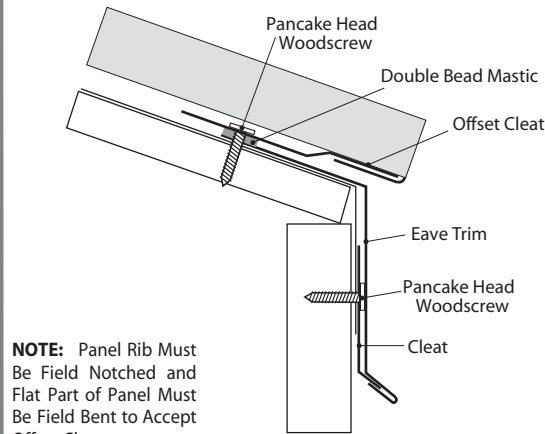

ACCESSORIES

Double Bead Mastic
Pancake Head Woodscrews
(12" On Center Typical)

FLASHING PROFILES

EAVE TRIM

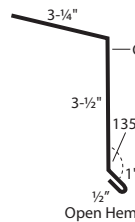

OFFSET CLEAT



CLEAT

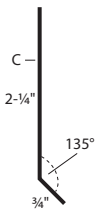

SQUARE/PLUMB EAVE DETAIL

- Attach eave trim to substrate with pancake head woodscrews, 24" on center.
- Hem panel and attach panel to Eave Trim. (Refer to pages 15 & 16 for details.)
- If 5K Gutter is to be installed, follow manufacturer's instructions.

Note: Ice and Water Shield is recommended for cold weather climates.

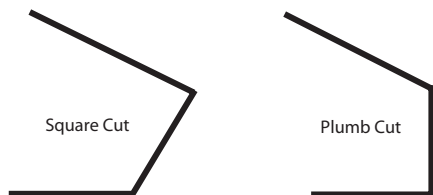

Note: Indicate whether the rafter is square cut or plumb cut and specify roof pitch.

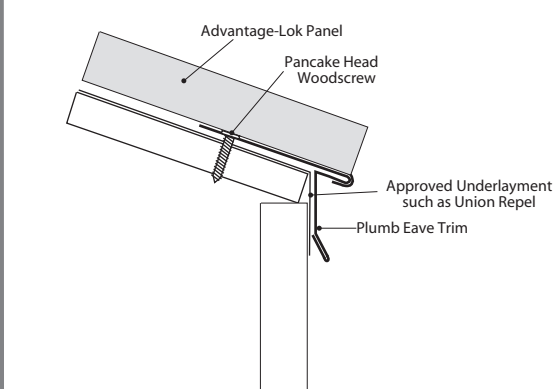

ACCESSORIES

Pancake Head Woodscrews
(12" On Center Typical)

FLASHING PROFILES

SQUARE EAVE

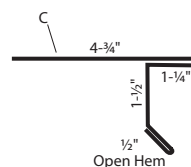

PLUMB EAVE

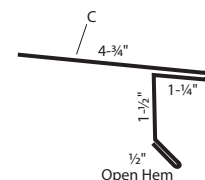

IMPORTANT – Application and design details are for illustrative purposes only and may not be appropriate for all environmental conditions and/or building designs. Projects should be engineered and installed to conform to applicable building codes, regulations, and accepted industry practices.

EAVE WITH GUTTER DETAIL

1. Attach Box Gutter, apply double bead mastic on top side of gutter, then place offset cleat on top of mastic and attach to substrate with 1" pancake head woodscrew spaced 24" on center.
2. Slide gutter hanger under open hem. Attach vertical leg with 1-1/2" woodscrew through the gutter hanger, box gutter, and into fascia board.
3. Allow panel to extend 1" beyond eave.
4. Hem panel, then slide hemmed edge over offset cleat.

**3:12 Slope
Minimum**

ACCESSORIES

Double Bead Mastic
Pop Rivets
Pancake Head Woodscrews
(12" On Center Typical)

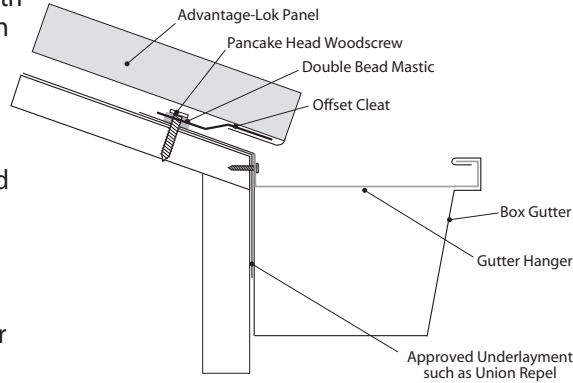

GUTTER DETAIL

FLASHING PROFILES

BOX GUTTER

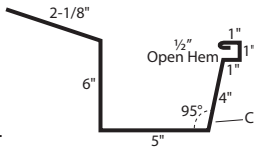

OFFSET CLEAT

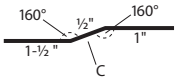

DOWNSPOUT WALL BRACKET

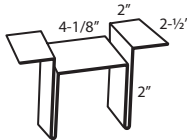

BOX GUTTER END

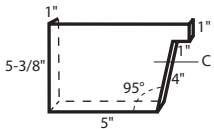

GUTTER HANGER



GUTTER SPLICE

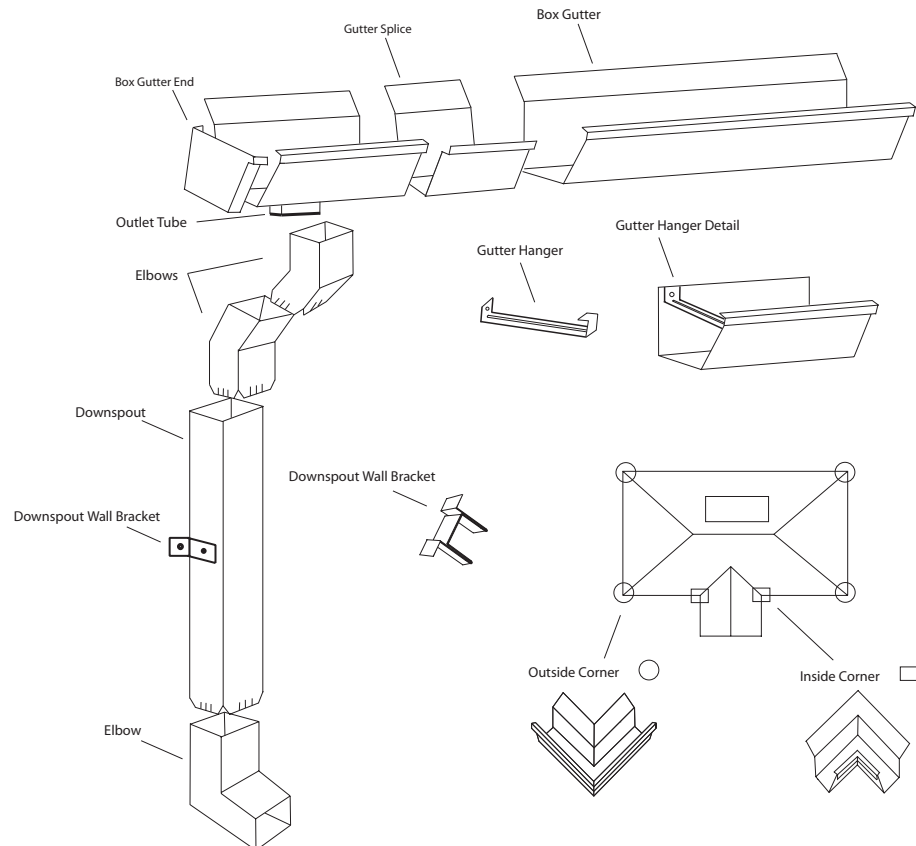
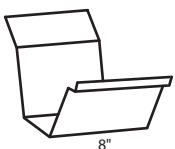

IMPORTANT – Application and design details are for illustrative purposes only and may not be appropriate for all environmental conditions and/or building designs. Projects should be engineered and installed to conform to applicable building codes, regulations, and accepted industry practices.

VALLEY DETAIL

**3:12 Slope
Minimum**

1. Attach Valley with 1" pancake head woodscrews 1" from the Valley outside edges, at each end, and in the center.
2. Leave panels back 4" from center line of valley.
3. Apply double bead mastic up 6-1/2" from each side of the water deflector along the valley length from eave to ridge.
4. Attach offset cleat on top of mastic. Use 1" pancake head woodscrews to attach off-set cleat to substrate 24" on center.
5. Slide hemmed panel over offset cleat. (Refer to pages 15 & 16 for details).
6. Place one 1" pancake head woodscrew every 24" in the fastening flange beginning at the eave and working up the ridge.

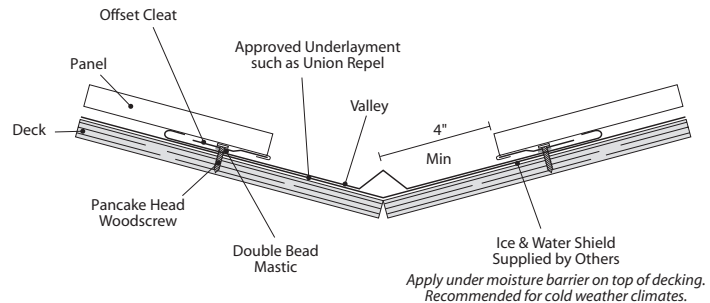

NOTE: Panel Rib Must Be Field Notched and Flat Part of Panel Must Be Field Bent to Accept Offset Cleat

FLASHING PROFILE

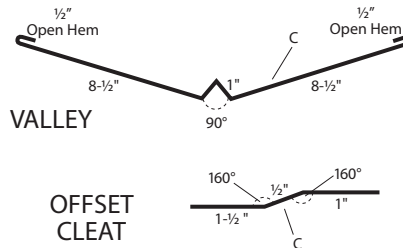

ACCESSORIES

Double Bead Mastic
Pancake Head Woodscrews
(24" On Center Typical)

Note: Endlap Valley Trim a minimum of 8".

PITCH CHANGE DETAIL

1. Before you install the Pitch Change, the lower roof panels must be installed.
2. Apply double bead mastic in the flat across the width of each lower roof panel 1" from the Pitch Change end.
3. Field cut Z-Closure to fit between the panel ribs, then place over the mastic and fasten with two 1" pancake head woodscrews.
4. Apply tube sealant to each end of the Z-Closure filling the gap between the end and panel ribs.
5. Hook the Pitch Change to the Z-Closure. Apply double bead mastic on top of the Pitch Change to allow the hemmed panel to snap over the offset cleat.
6. Fasten with pancake head woodscrews 12" on center. Secure with pop rivets (Optional). Hook panel over the offset cleat.

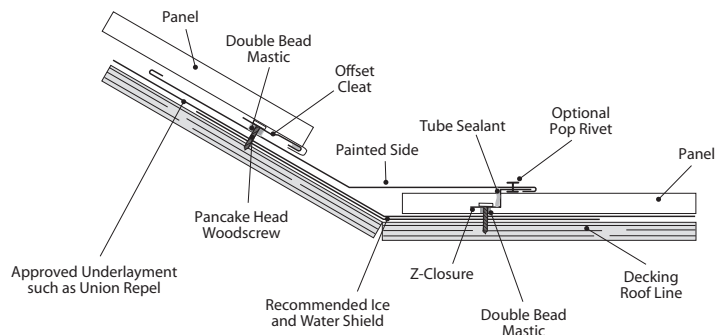

FLASHING PROFILE

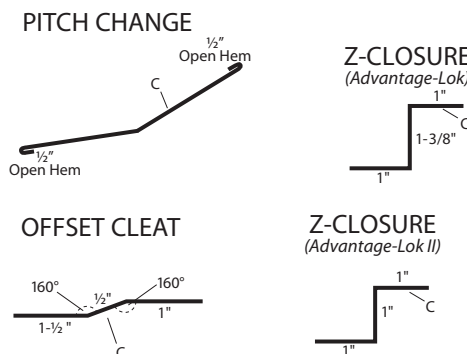

ACCESSORIES

Pancake Head Woodscrews
(12" On Center Typical)
Double Bead Mastic
Tube Sealant
Optional Pop Rivets
(12" On Center Typical)

IMPORTANT – Application and design details are for illustrative purposes only and may not be appropriate for all environmental conditions and/or building designs. Projects should be engineered and installed to conform to applicable building codes, regulations, and accepted industry practices.

SQUARE RAKE DETAIL

1. Fasten Square Rake with pancake head woodscrews 24" on center.
2. Refer to page 15 for Square Rake hemming detail.
3. Hook hemmed panel to Square Rake and secure with pancake head woodscrews.

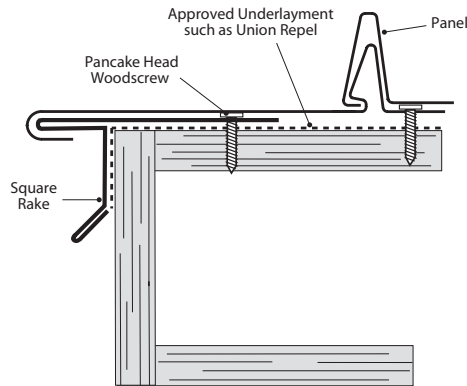

FLASHING PROFILE

SQUARE RAKE

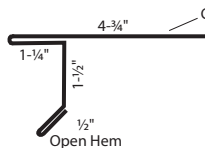

ACCESSORIES

Pancake Head
Woodscrews
(12" On Center Typical)

BOX RAKE DETAIL

1. If panel rib will not be beneath the rake trim, you must turn up the sheet 1-3/8".
2. Measure where the Z-Closure needs to be attached to the panel.
3. Apply roll mastic to the bottom of the Z-Closure.
4. Attach the Z-Closure to the panel 24" on center with pancake head woodscrews.
5. Decide where to fasten fascia side cleat and install with pancake head woodscrews 24" on center.
6. Snap rake trim over the cleat and the Z-Closure. Secure with pop rivets.

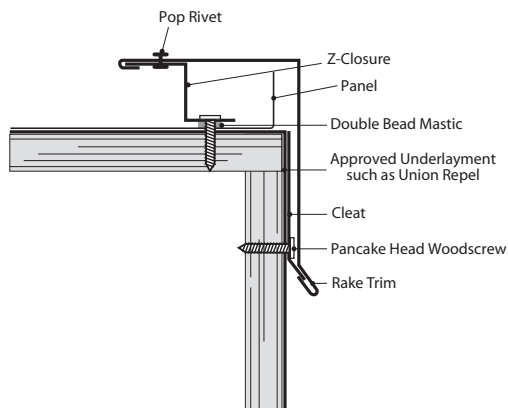

ACCESSORIES

Double Bead Mastic
Pancake Head Woodscrews
(12" On Center Typical)
Optional Pop Rivets
(12" On Center Typical)

FLASHING PROFILES

RAKE

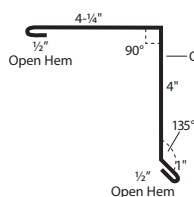

CLEAT

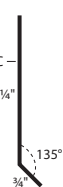

Z-CLOSURE (Advantage-Lok)

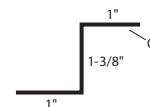

Z-CLOSURE (Advantage-Lok II)

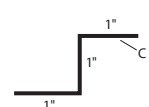

IMPORTANT – Application and design details are for illustrative purposes only and may not be appropriate for all environmental conditions and/or building designs. Projects should be engineered and installed to conform to applicable building codes, regulations, and accepted industry practices.

TYPICAL LAPPING DETAIL

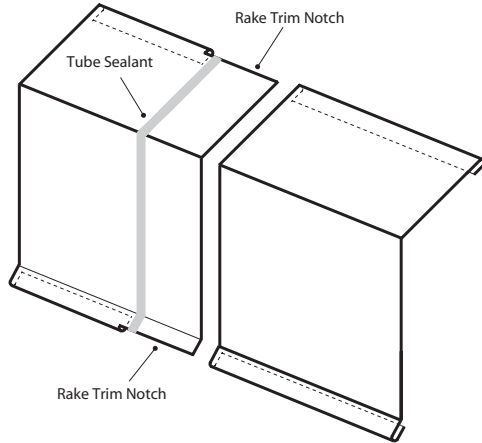

This detail shows the rake trim, but it can be used for similar trims, such as the valley, hip, ridge, pitch change, high side peak, end wall, and side wall.

SIDE WALL DETAIL

1. Measure where the Z-Closure needs to be attached to panel to attach the Side Wall.
2. Apply mastic to the panel where the Z-Closure will be attached. The colored side of the Z-Closure should face the exposed side.
3. If panel rib will not be beneath the Side Wall, you must turn up the sheet 1-3/8".
4. Fasten the panel to the substrate.
5. Hook the Side Wall to the Z-Closure. Secure with pop rivets. (Optional)
6. Attach a counter flashing or reglet to the wall above the Side Wall flashing.

For panels less than 25', you can screw the Z-Closure directly into the panel and substrate.

To do this:

1. Apply roll mastic to the bottom of the Z-Closure.
2. Attach the Z-Closure to the panel 24" on center with pancake head woodscrews.
3. Follow steps 3, 5, & 6 to complete installation.

**3:12 Slope
Minimum**

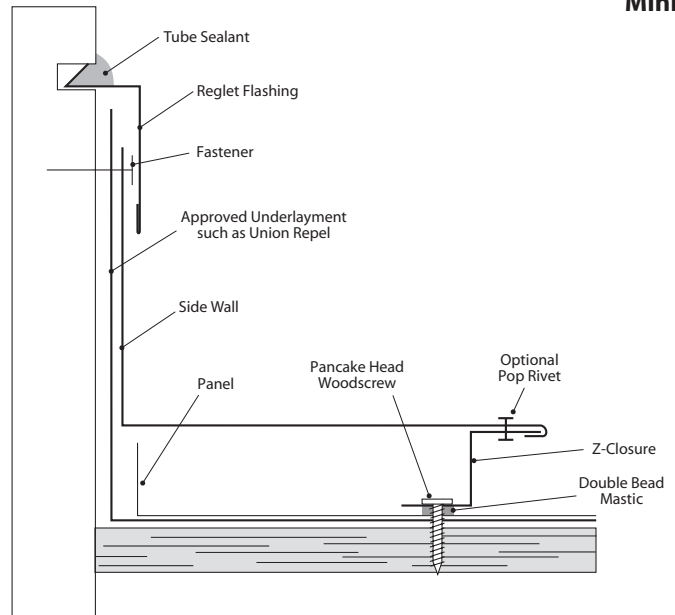

FLASHING PROFILES

SIDE WALL

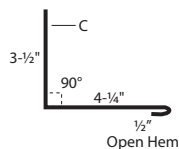

REGLET

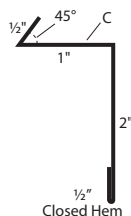

Z-CLOSURE (Advantage-Lok)

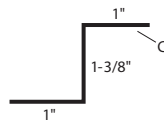

Z-CLOSURE (Advantage-Lok II)

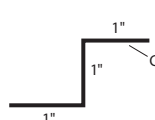

ACCESSORIES

- Double Bead Mastic
- Tube Caulk
- Optional Pop Rivets
(12" On Center Typical)
- Pancake Head Screws
(12" On Center Typical)

IMPORTANT – Application and design details are for illustrative purposes only and may not be appropriate for all environmental conditions and/or building designs. Projects should be engineered and installed to conform to applicable building codes, regulations, and accepted industry practices.

HIP DETAIL

**3:12 Slope
Minimum**

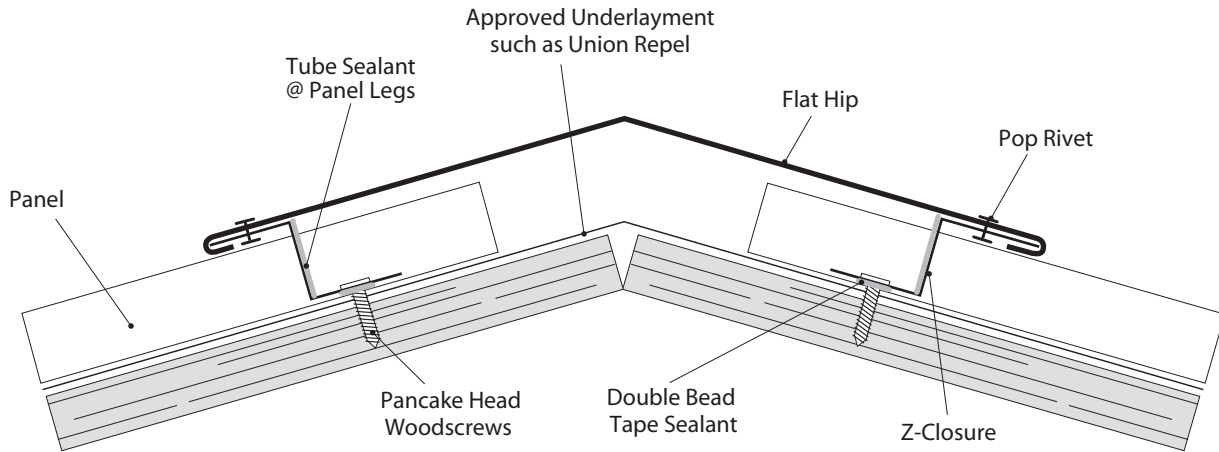

1. Cut Z-Closure to fit between panel ribs and set in double bead tape sealant.
2. Fasten to substrate with pancake head woodscrews @ 4" O.C.
3. Caulk with tube sealant inside of Z-Closure along full panel leg.
4. Hook Hip onto Z-Closure.
5. Pop rivet both sides of Flat Hip @ 24" O.C. to top of Z-Closure.

FLASHING PROFILES

ACCESSORIES

FLAT HIP

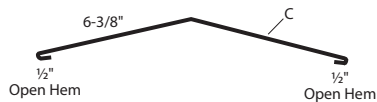

STEP HIP (Optional)

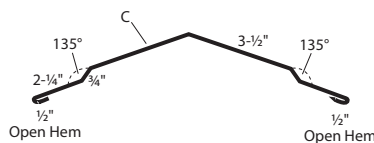

Z-CLOSURE (Advantage-Lok)

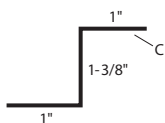

Z-CLOSURE (Advantage-Lok II)

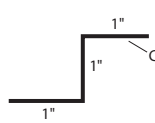

Tube Sealant

Pancake Head
Woodscrews

Pop Rivets

IMPORTANT – Application and design details are for illustrative purposes only and may not be appropriate for all environmental conditions and/or building designs. Projects should be engineered and installed to conform to applicable building codes, regulations, and accepted industry practices.

VENTED FLAT RIDGE DETAIL

**3:12 Slope
Minimum**

1. Place double bead mastic on bottom of vented closure strip closest to ridge.
2. Place vented closure strip on top of panel 1" from edge of Flat Ridge with V-shaped weep holes facing out.
3. Place double bead mastic on top of front closure closest to eave.
4. Hook both sides of the hemmed Flat Ridge over the Vent Retainer. Secure with pop rivets.

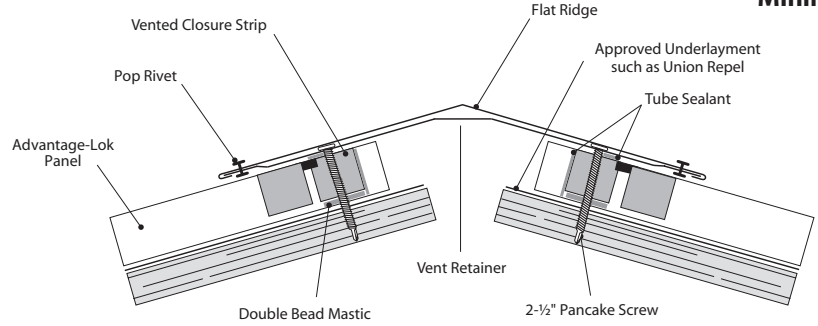

FLASHING PROFILES

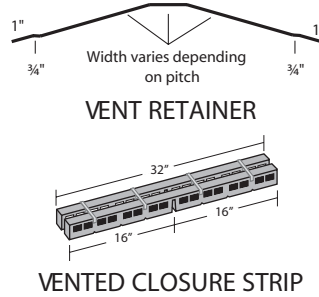
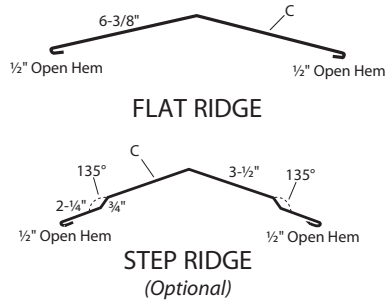

ACCESSORIES

- Vented Closure Strip
- Tube Sealant
- Double Bead Mastic
- 2-1/2" Pancake Head Woodscrews
- Optional Pop Rivets (12" On Center Typical)

NON-VENTED FLAT RIDGE DETAIL

**3:12 Slope
Minimum**

1. Field cut Z-Closure to fit pan of roof sheet.
2. Apply double bead mastic to the bottom of the Z-Closure. Make sure colored side is facing out.
3. Place Z-Closure in the pan of the panel and attach with pop rivets or pancake head woodscrews.
4. Apply tube sealant to both sides of the Z-Closure where the trim meets the panel rib.
5. Hook both sides of the hemmed Step Ridge onto the Z-Closure. Secure with pop rivets.

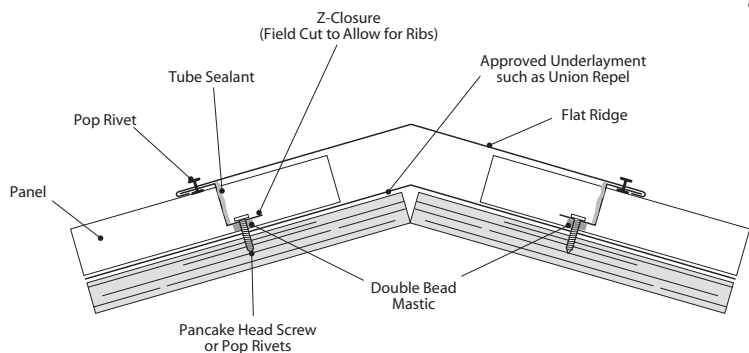

FLASHING PROFILES

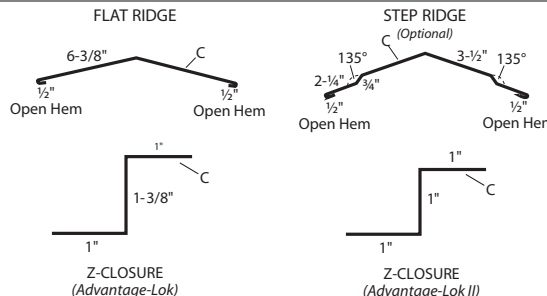

ACCESSORIES

- Tube Sealant
- Double Bead Mastic
- Pancake Head Woodscrews (3 Per Panel Rib)
- Optional Pop Rivets (12" On Center Typical)

IMPORTANT – Application and design details are for illustrative purposes only and may not be appropriate for all environmental conditions and/or building designs. Projects should be engineered and installed to conform to applicable building codes, regulations, and accepted industry practices.

VENTED SINGLE SLOPE RIDGE DETAIL

1. Attach cleat with 1" pancake head woodscrews.
2. Place double bead mastic on bottom of vented closure strip closest to ridge and place mastic on top of vented closure strip closest to eave.
3. Place vented closure strip on top of panel 1" from edge of Single Slope Ridge with V-shaped weep holes facing out.
4. Snap Single Slope Ridge over cleat and pop rivet to top of Advantage Lok ribs.

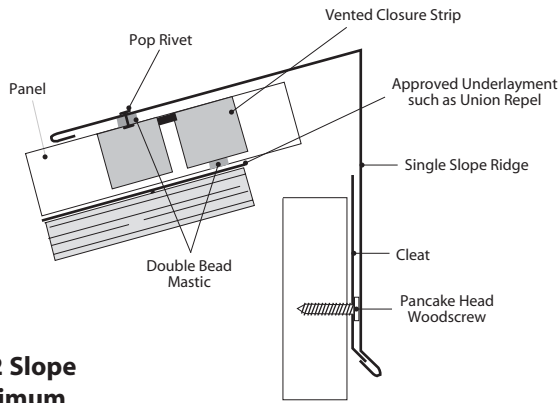

3:12 Slope Minimum

ACCESSORIES

- Vented Closure Strip
- Double Bead Mastic
- Pop Rivet (1 Per panel Rib)
- Pancake Head Woodscrews (24" On Center Typical)

FLASHING PROFILES

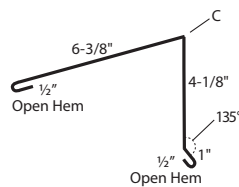

SINGLE SLOPE RIDGE

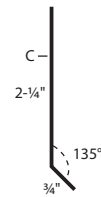

CLEAT

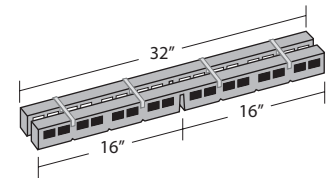

VENTED CLOSURE STRIP

NON-VENTED SINGLE SLOPE RIDGE DETAIL

1. Attach cleat with 1" pancake head woodscrews.
2. Field cut Z-Closure to fit pan of roof sheet.
3. Apply double bead mastic to the bottom of the Z-Closure. Make sure colored side is facing out.
4. Place Z-Closure in the pan of the panel and attach with pancake head woodscrews.
5. Apply tube sealant to both sides of the Z-Closure where the trim meets the panel rib.
6. Hook Single Slope Ridge over cleat and the Z-Closure. Secure with pop rivets. (Optional)

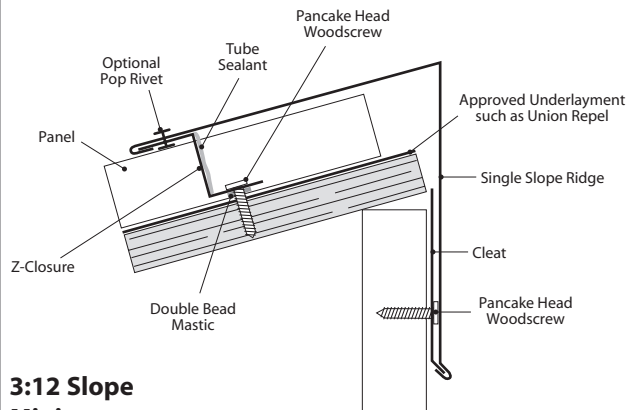

3:12 Slope Minimum

ACCESSORIES

- Tube Sealant
- Double Bead Mastic
- Pancake Head Woodscrews (3 Per Panel Rib)
- Optional Pop Rivets (12" On Center Typical)

FLASHING PROFILES

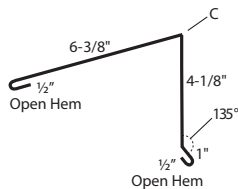

SINGLE SLOPE RIDGE

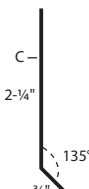

CLEAT

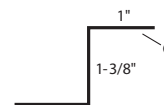

Z-CLOSURE (Advantage-Lok)

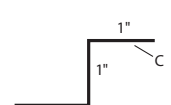

Z-CLOSURE (Advantage-Lok II)

IMPORTANT – Application and design details are for illustrative purposes only and may not be appropriate for all environmental conditions and/or building designs. Projects should be engineered and installed to conform to applicable building codes, regulations, and accepted industry practices.

VENTED END WALL DETAIL

- Place double bead mastic on bottom of back piece of vented closure strip. Place mastic on top of closure closest to eave.
- Place closure on top of panel 1" from edge of End Wall with V-shaped weep hole facing out.
- Pop rivet End Wall to top of Advantage-Lok ribs.
- Install a counter flashing or reglet to the wall above the End Wall.

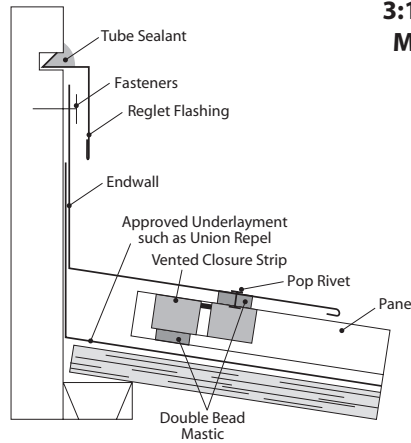

**3:12 Slope
Minimum**

ACCESSORIES

- Vented Closure Strip
- Double Bead Mastic
- Pop Rivets (12" On Center Typical)
- Fastener (12" On Center Typical)

FLASHING PROFILES

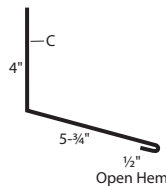

END WALL

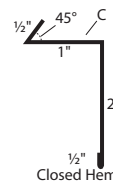

REGLET

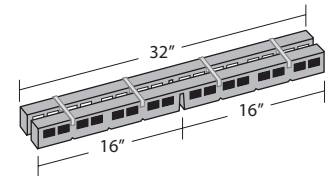

VENTED CLOSURE STRIP

NON-VENTED END WALL DETAIL

- Field cut Z-Closure to fit pan of roof sheet.
- Apply double bead mastic to the bottom of the Z-Closure. Make sure colored side is facing out.
- Place Z-Closure in the pan of the panel and attach with pop rivets or pancake head woodscrews.
- Apply tube sealant to both sides of the Z-Closure where the trim meets the panel rib.
- Hook the End Wall to the Z-Closure. Secure with pop rivets. (Optional)
- Install a counter flashing or reglet to the wall above the End Wall.

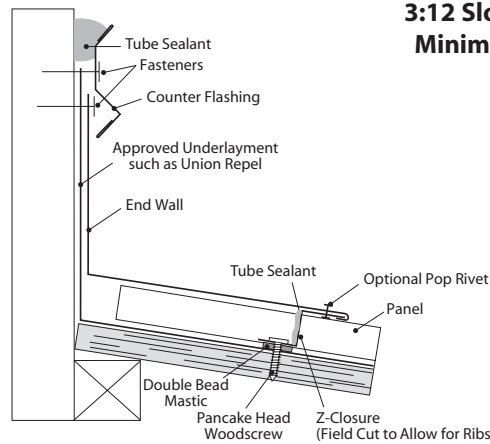

**3:12 Slope
Minimum**

ACCESSORIES

- Tube Sealant
- Double Bead Mastic
- Pancake Head Woodscrews (3 Per Panel Rib)
- Optional Pop Rivets (12" On Center Typical)

FLASHING PROFILES

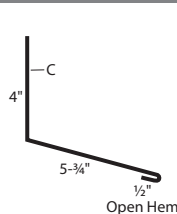

END WALL

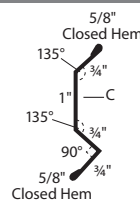

COUNTER FLASHING

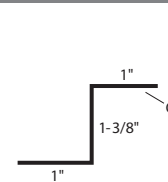

Z-CLOSURE
(Advantage-Lok)

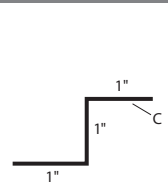

Z-CLOSURE
(Advantage-Lok II)

IMPORTANT – Application and design details are for illustrative purposes only and may not be appropriate for all environmental conditions and/or building designs. Projects should be engineered and installed to conform to applicable building codes, regulations, and accepted industry practices.

SILL DETAIL

1. Attach Sill to substrate with pancake head woodscrew.

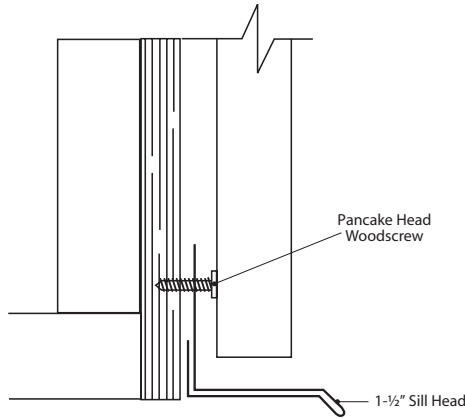

ACCESSORIES

Pancake Head Woodscrews
(24" On Center Typical)

FLASHING PROFILES

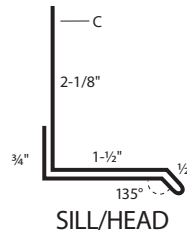

SILL TO SOFFIT DETAIL

1. Apply tube sealant to back leg of Sill to Soffit. Refer to illustration.
2. Attach Sill to Soffit.

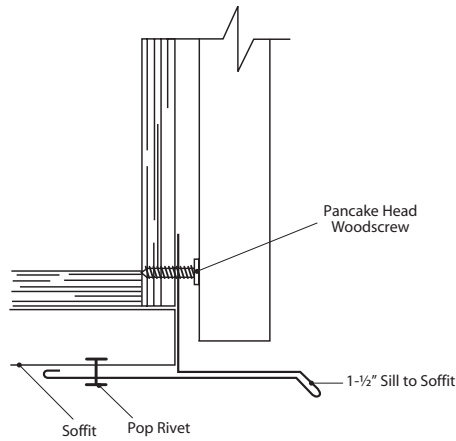

ACCESSORIES

Pop Rivets
(12" On Center Typical)

Pancake Head Woodscrews
(12" On Center Typical)

FLASHING PROFILES



IMPORTANT – Application and design details are for illustrative purposes only and may not be appropriate for all environmental conditions and/or building designs. Projects should be engineered and installed to conform to applicable building codes, regulations, and accepted industry practices.

VENT PIPE FLASHING DETAIL

1. Cut pipe boot at appropriate pipe diameter.
2. Slide the pipe boot down over the pipe using water to lubricate it if necessary.
3. Form base to fit profile on the roof panel.
4. Seal between base and roof with tube sealant.
5. Fasten the pipe boot with 1- $\frac{1}{2}$ " woodscrew at 1- $\frac{1}{2}$ " centers to complete the seal.

Available in nine different sizes to fit pipes from $\frac{1}{4}$ " to 19" in diameter.

Three styles available:

1. EPDM Black or Grey
2. Silicone (Heat Tempered 100° to 450°)
3. Retrofit (Boot fits around pipe)

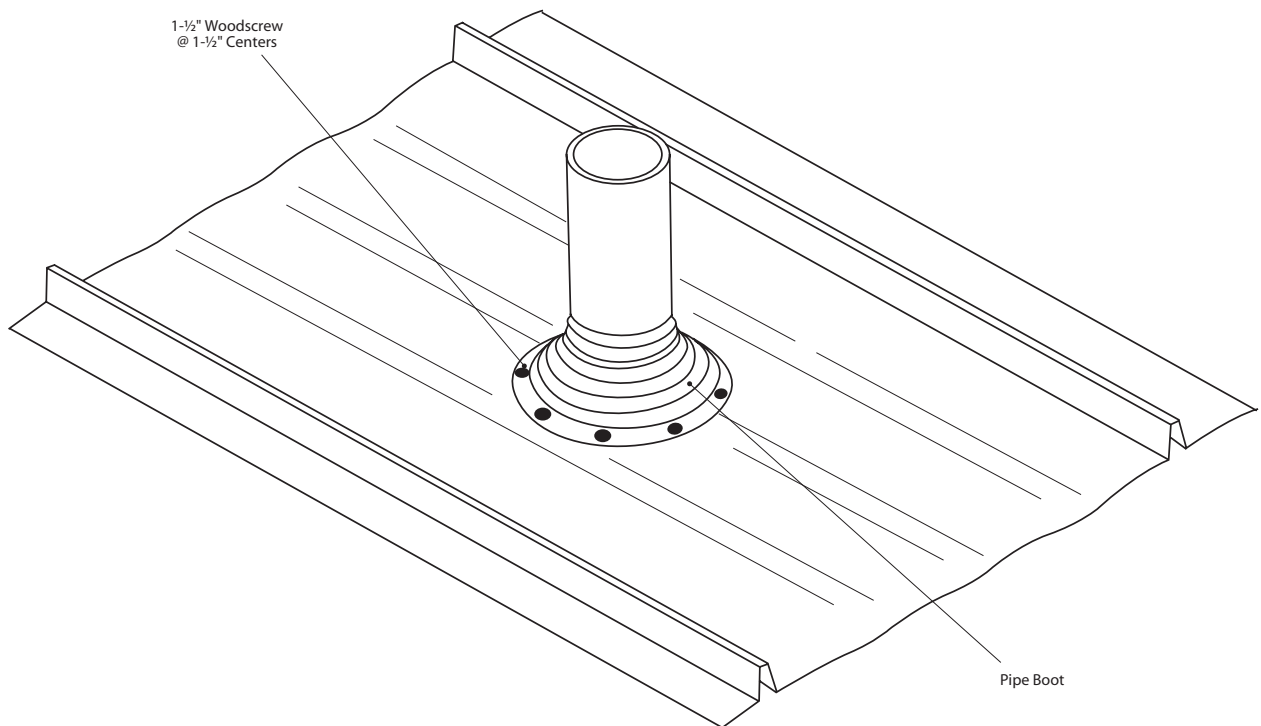

IMPORTANT – Application and design details are for illustrative purposes only and may not be appropriate for all environmental conditions and/or building designs. Projects should be engineered and installed to conform to applicable building codes, regulations, and accepted industry practices.

CURB DETAIL (Chimneys & Skylights)

STEP 1

Install lower panels around curb.

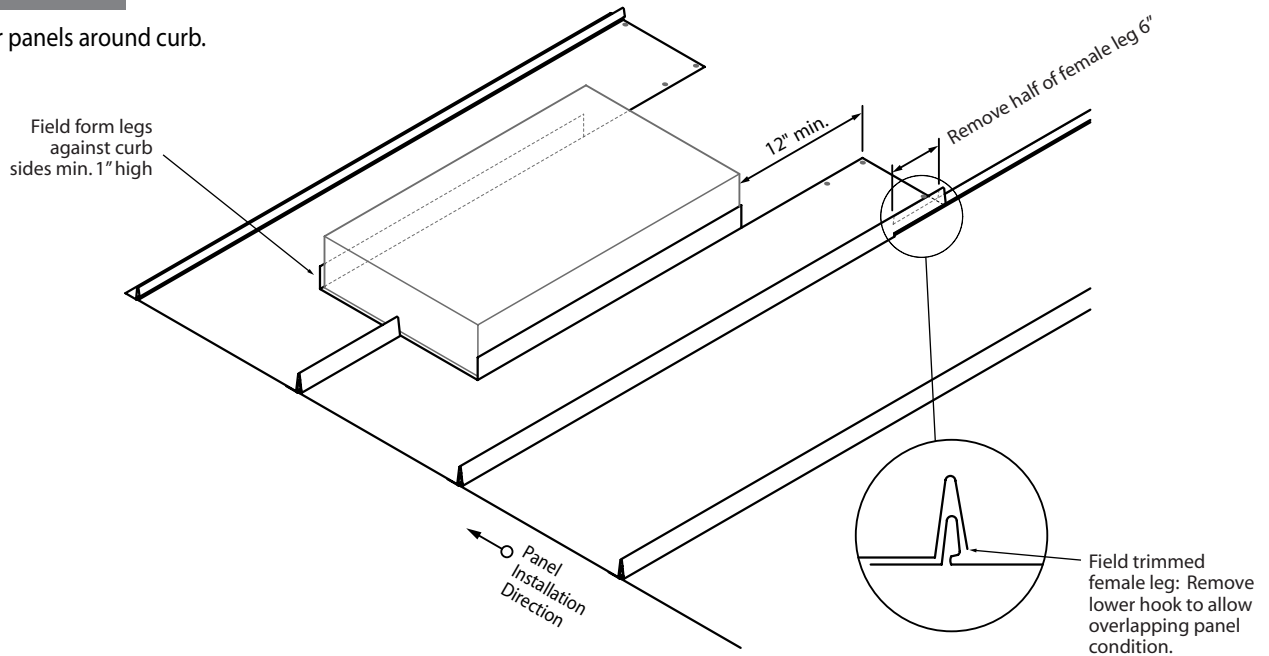

STEP 2

Apply Z-Closure flashing over double bead mastic.

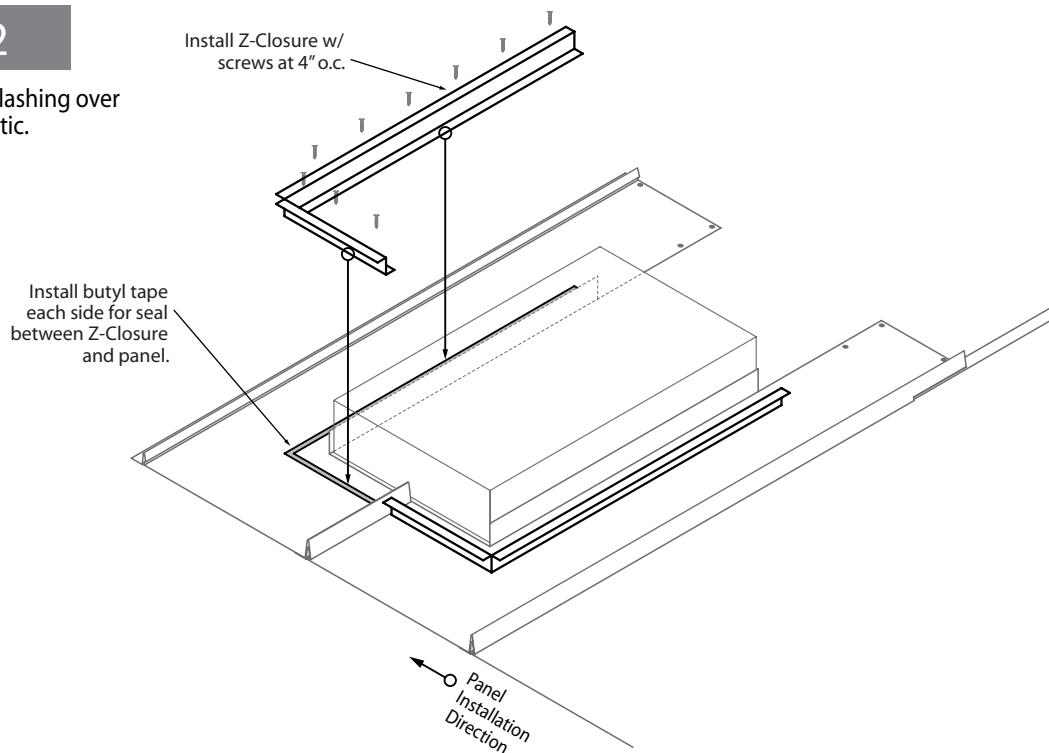

IMPORTANT – Application and design details are for illustrative purposes only and may not be appropriate for all environmental conditions and/or building designs. Projects should be engineered and installed to conform to applicable building codes, regulations, and accepted industry practices.

CURB DETAIL (Chimneys & Skylights) (cont.)

STEP 3

Install sidewall and high wall flashings atop Z-Closure.

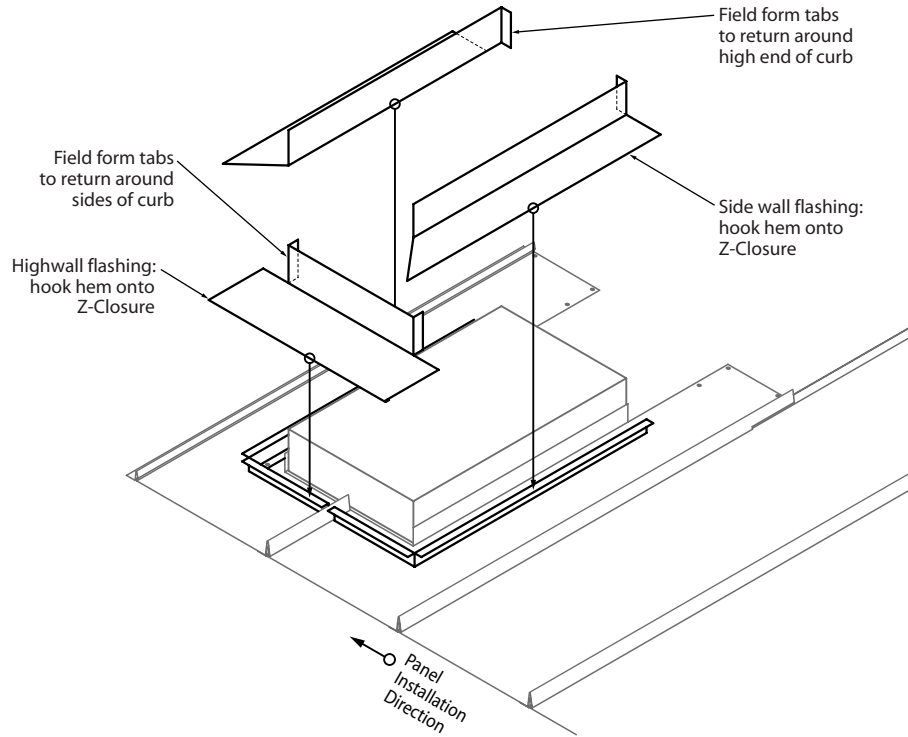

STEP 4

Install low wall flashing.

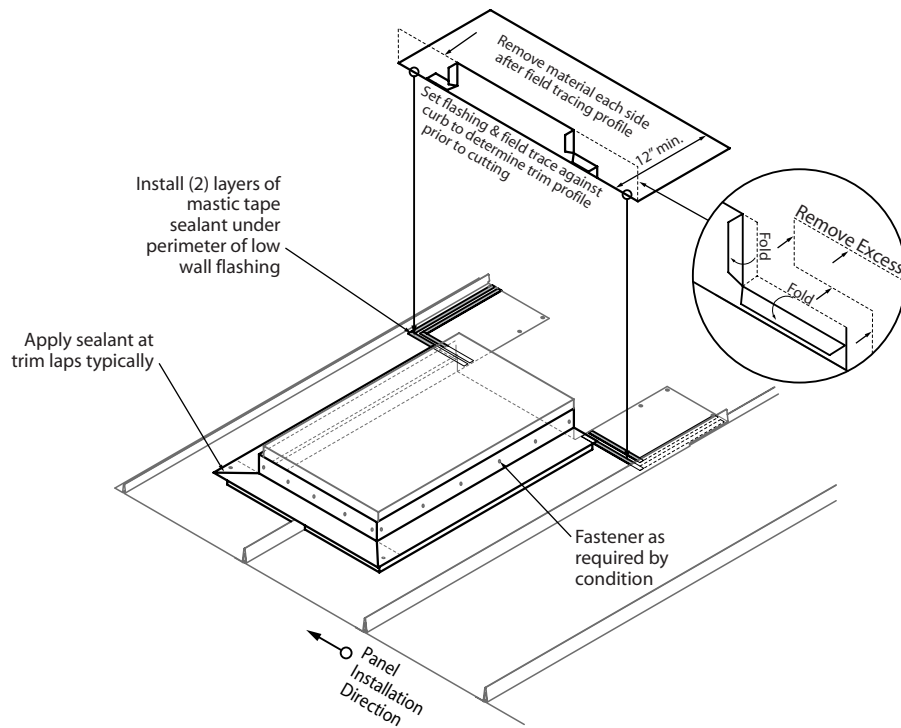

IMPORTANT – Application and design details are for illustrative purposes only and may not be appropriate for all environmental conditions and/or building designs. Projects should be engineered and installed to conform to applicable building codes, regulations, and accepted industry practices.

CURB DETAIL (Chimneys & Skylights) (cont.)

STEP 5

Install cleat and prepare for upper panel installation.

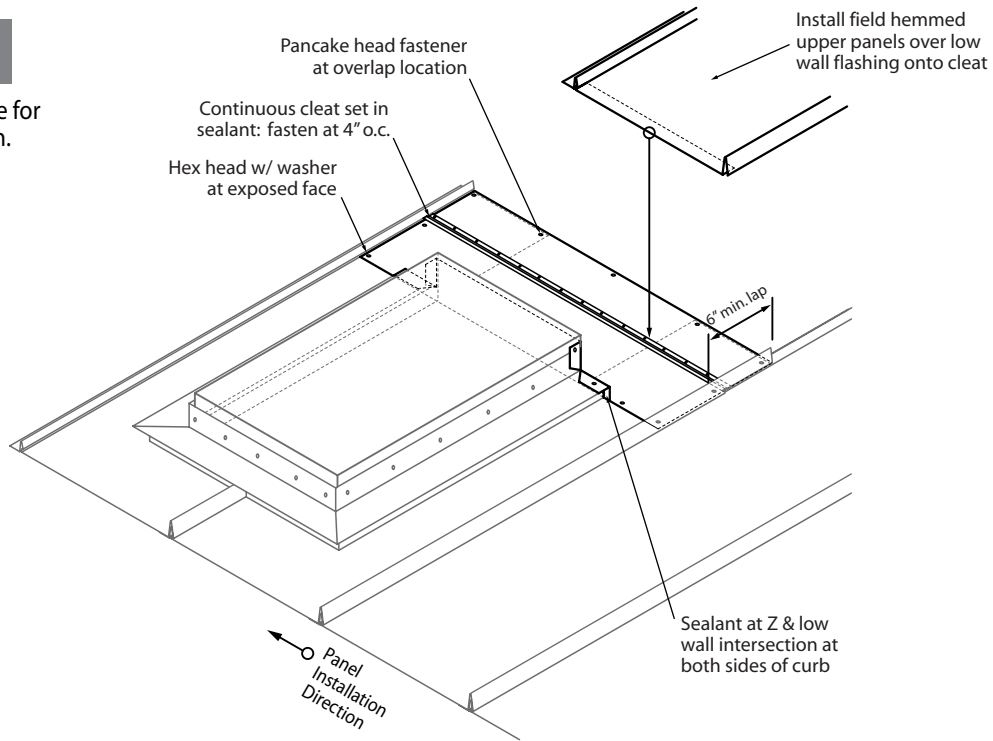

STEP 6

Install final panel above curb.

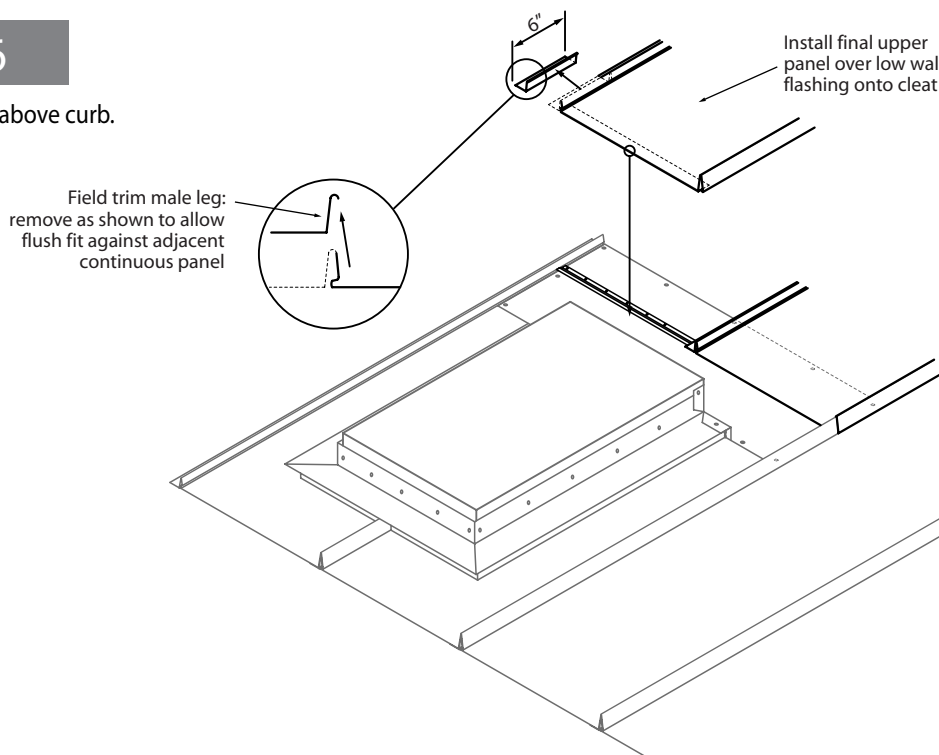

IMPORTANT – Application and design details are for illustrative purposes only and may not be appropriate for all environmental conditions and/or building designs. Projects should be engineered and installed to conform to applicable building codes, regulations, and accepted industry practices.



PO Box 229 • Fayetteville, NC 28302 • 888-MTL-ROOF (685-7663) • Fax: 800-586-2498

SPENCER STEEL SUPPLY
SPENCER, NC

ANDERSON STEEL SUPPLY
ANDERSON, SC

ORANGE STEEL ROOFING
ORANGE, VA

TIFTON STEEL PRODUCTS
TIFTON, GA

UNICO METAL PRODUCTS
OCALA, FL

VICKSBURG METAL PRODUCTS
VICKSBURG, MS

DAYTON METALS
DAYTON, OH

GREAT PLAINS METALS
OKLAHOMA CITY, OK

NORTHEAST DIVISION
SCRANTON, PA